



INSTRUCTION MANUAL

1 / 10 SCALE RADIO CONTROLLED GAS POWERED RACING TOURING CAR

Width/198 mm (7.8")
 Height/104 mm (4.1")
 Track: 172 mm (6.8")
 Length/380 mm (15.0")
 Wheelbase/260 mm (10.2")
 Gear Ratio/Low 7.55:1/High 5.82:1
 Ground Clearance Front~Rear/4.5~5.5 mm (0.18-0.22")



INDEX

■ VISION RTR/Required for Operation.....	2-3
■ Assembly.....	4-13
■ General Information.....	14-18
■ Parts Name List.....	19-22
■ Optional Parts List.....	23-24
■ Foam Tire Part List.....	25
■ Exploded View (1).....	26-27
■ Exploded View (2).....	28
■ Engine Parts List.....	29
■ Set-up Sheet.....	30-31



This radio controlled racing car is not a toy!
 This high-performance R/C model is recommended for ages 14 and older.



Thank you for purchasing the GS Racing **VISION RTR** nitro powered radio controlled touring car. Please read through all the instructions carefully before you attempt to operate your **VISION RTR**. This manual contains building steps and instructions to help you for the assemble/disassemble on your **VISION RTR**. Follow the directions in this manual closely so you don't encounter any problems on start up. We hope that you will enjoy your new GS Racing nitro **VISION RTR**. If you ever have any questions or need the further setup help, please feel free to contact our official dealers. See you at the track!

-GS Racing-

Required Equipment for Operation

1. Tools required for building and maintenance:

- Hobby knife
- Needle nose pliers
- Precision ruler or caliper
- Phillips screwdriver (#0, #1, #2)
- Hobby scissors
- Wire cutters
- Thread locking compound
- CA glue
- Rubber cement
- Snap ring pliers

- Precision Ruler or Caliper

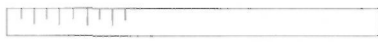

- Hobby Scissors

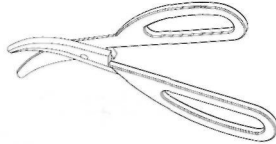

- Hobby Knife

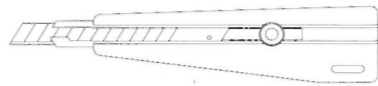

- Wire Cutters

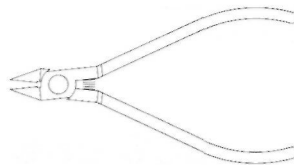

- Hex Wrench

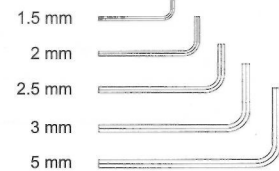

- Needle Nose Pliers

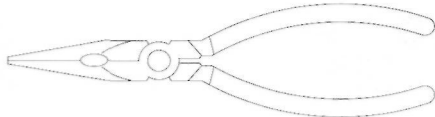

- Thread Locking Compound

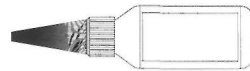

- Cross Wrench

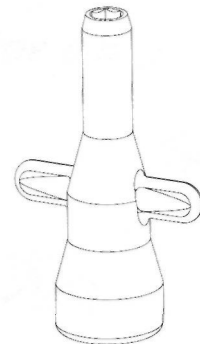

Cross Wrench 7 mm



Wrench 8 mm

- Phillips Screwdriver (#0, #1, #2)

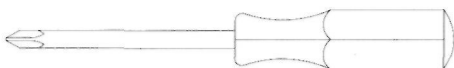

- CA Glue & Rubber Cement



WARNING!

Do not use a power screwdriver to install screws into nylon or plastic materials. The fast rotation speed can heat up the screws being installed. They can then break the molded parts or strip the threads during installation.

2. Additional items needed for operation Vision RTR #GS 410412 (Gsc 412):

- 4-AA batteries for receiver /8-AA batteries transmitter
- Shock, diff., and air filter oils, and grease
- Glow igniter, glow fuel, and fuel bottle

1. Front Gear Differential

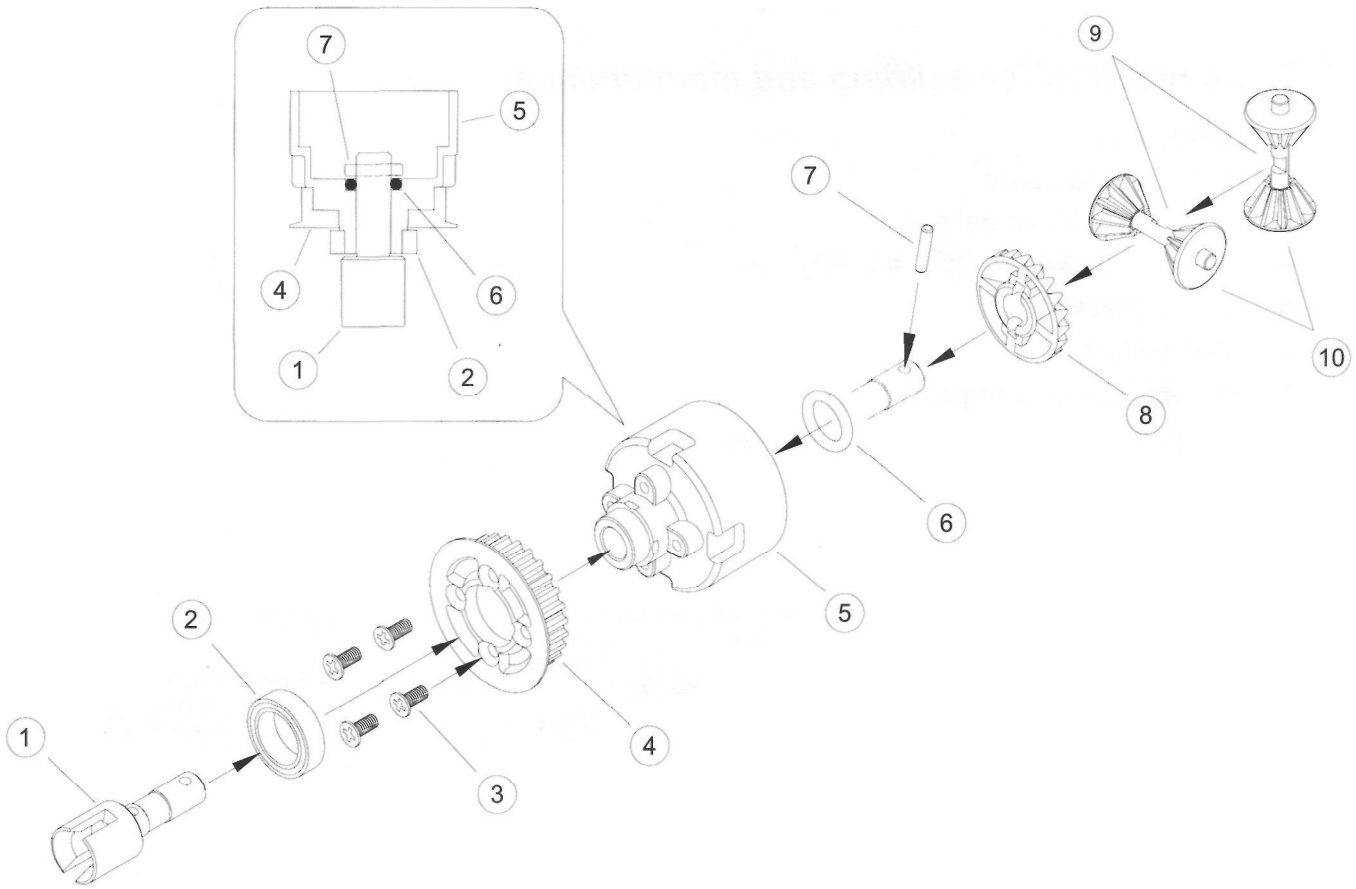

2. Front Gear Differential

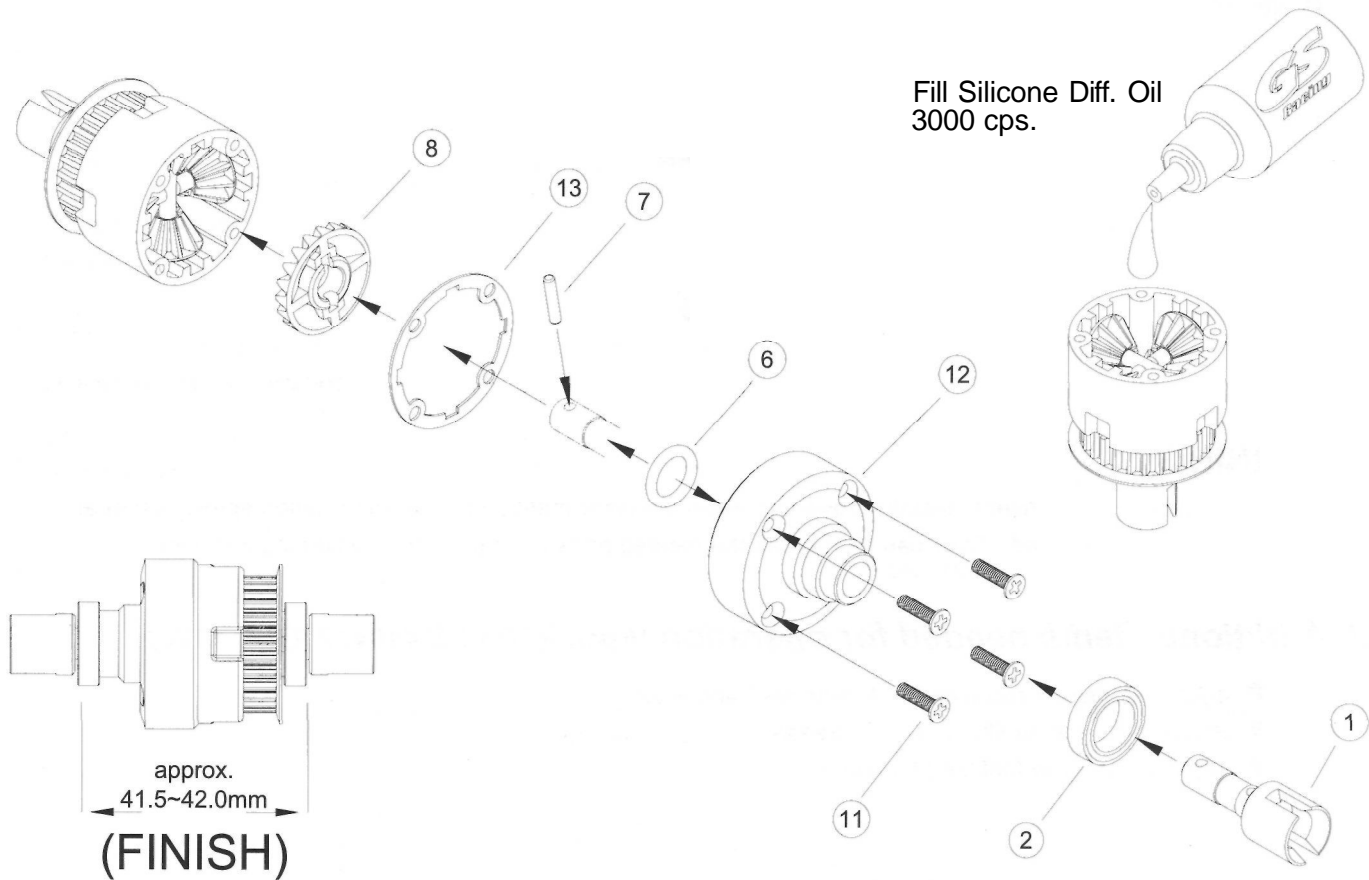

3. Rear Gear Differential

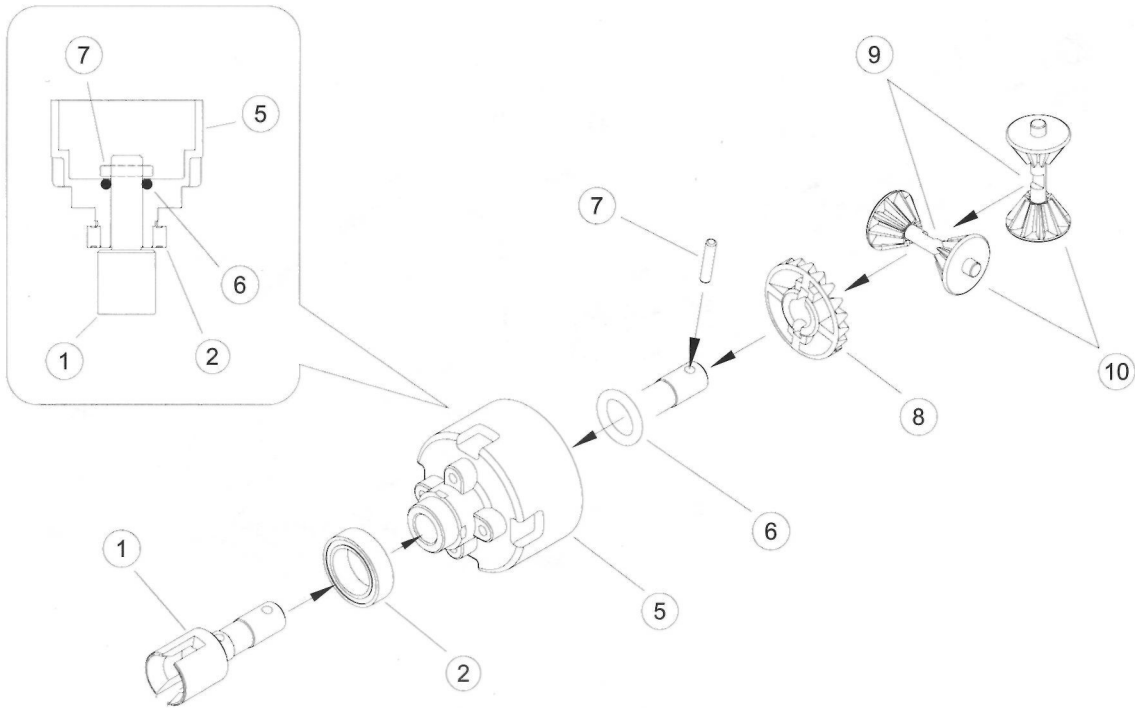

4. Rear Gear Differential

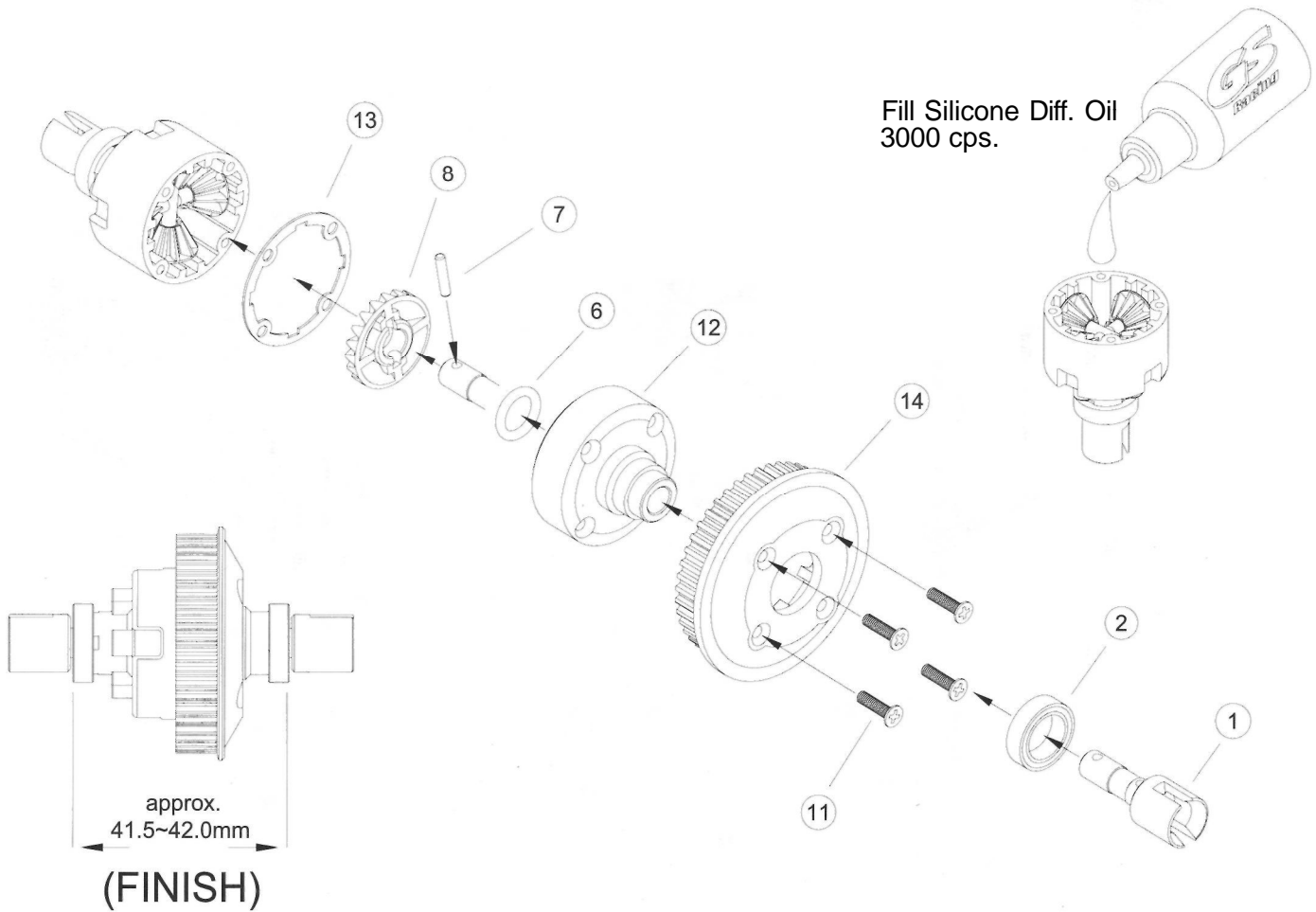

5. Front Chassis Assembly

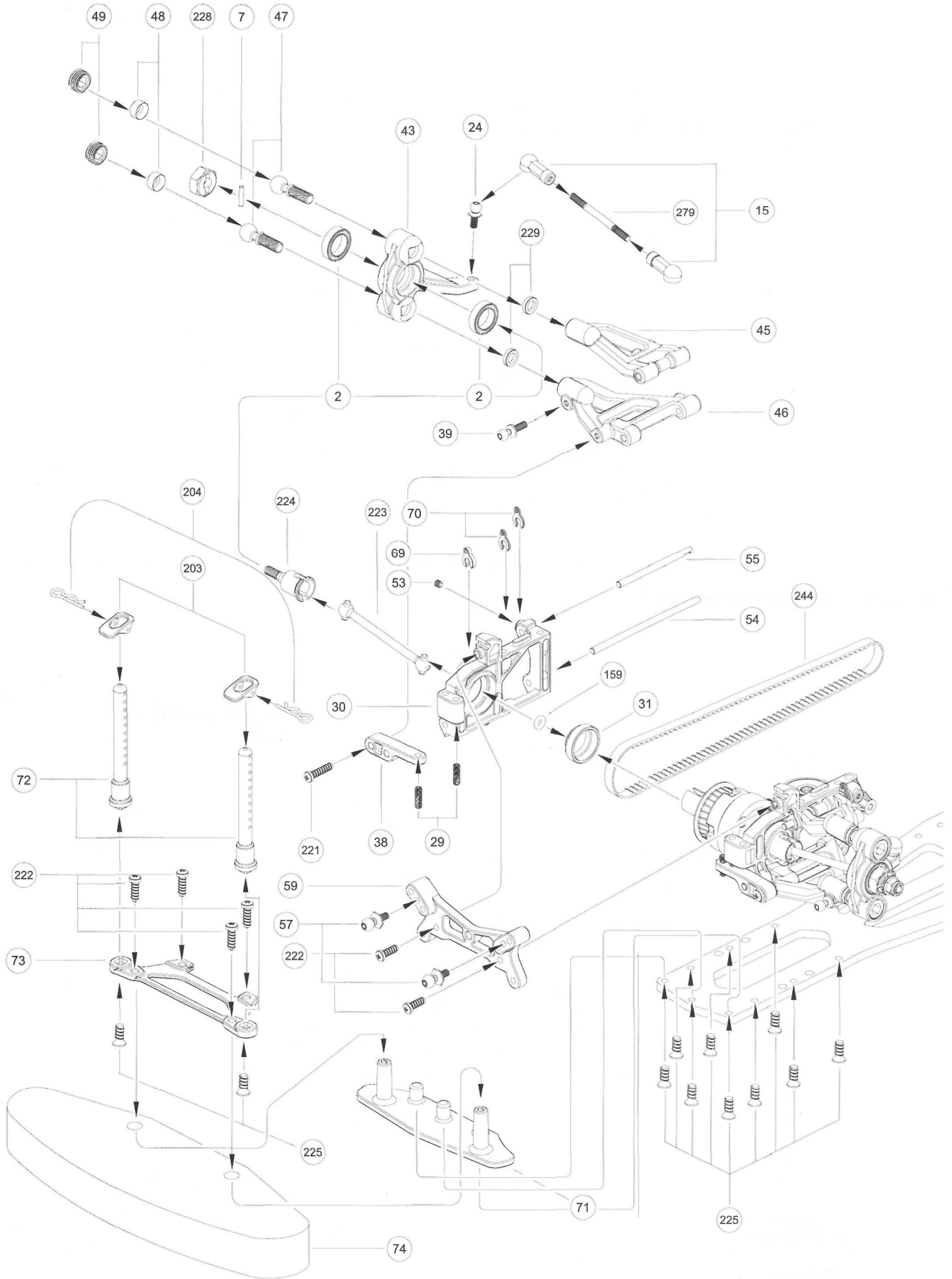

6. Rear Chassis Assembly

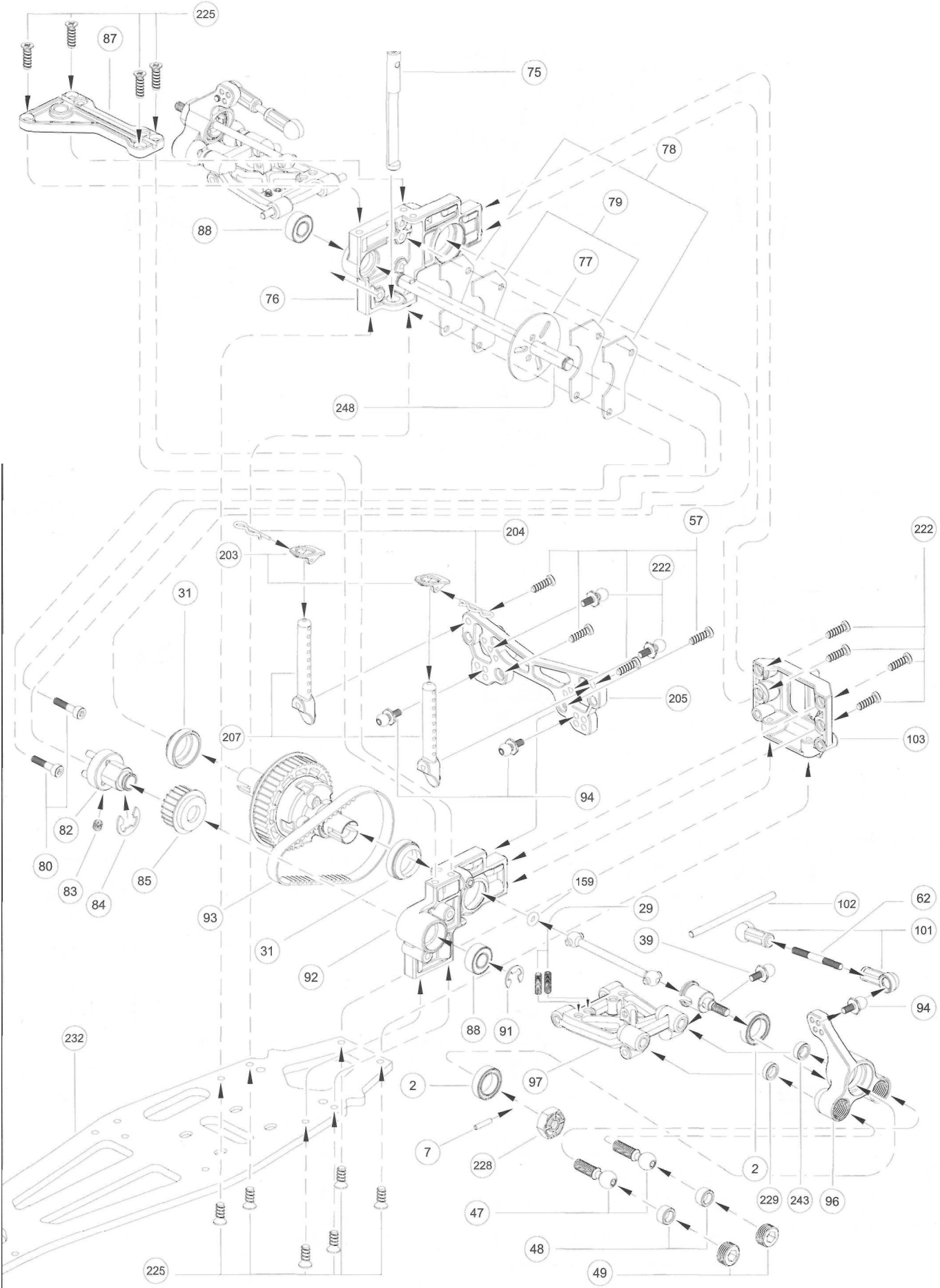

7. Shocks & Shock Springs

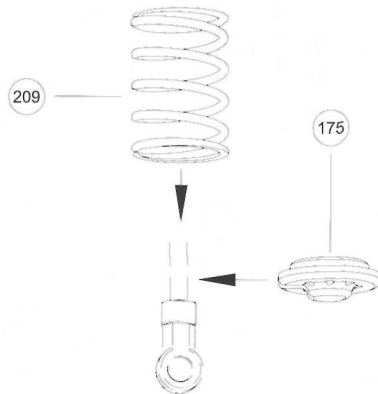
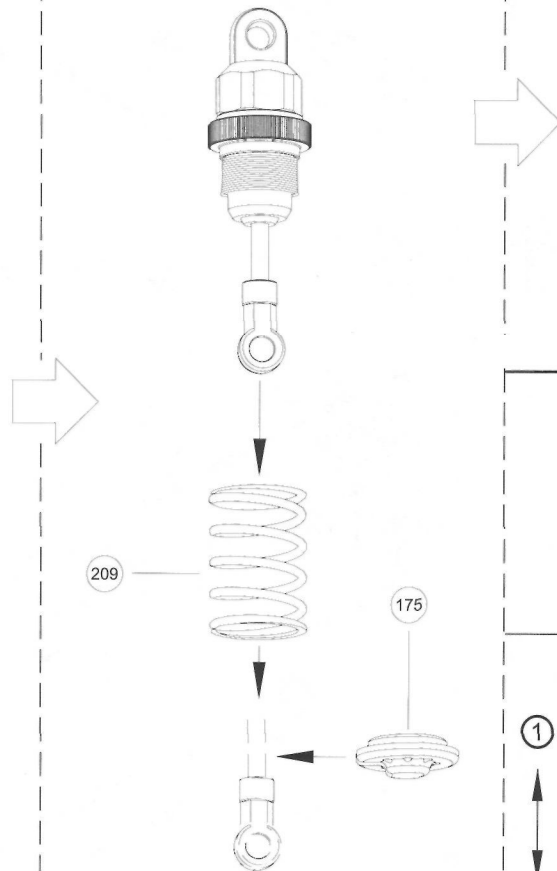
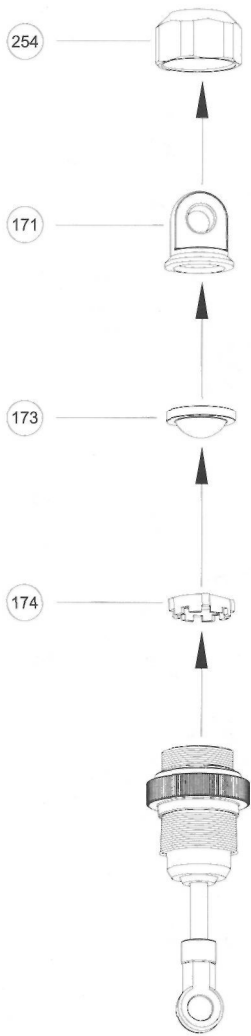
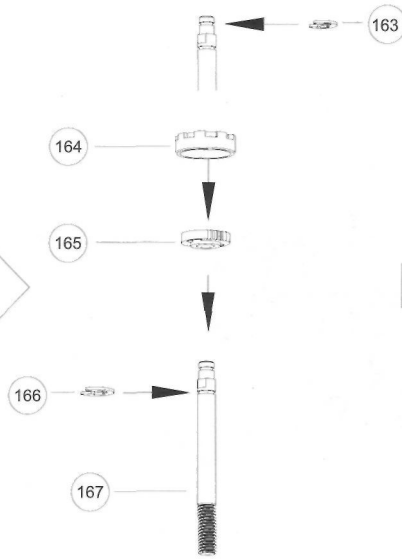
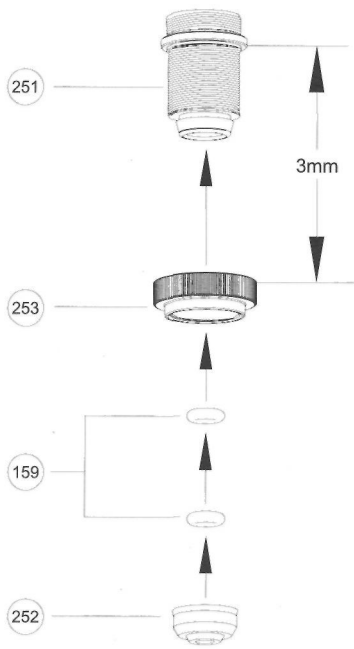

※ Please select with your liking

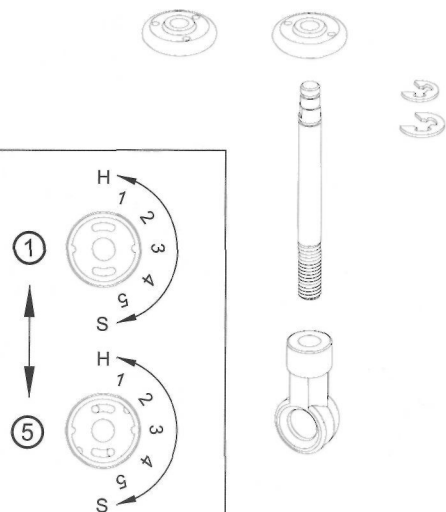

8. Transmission & Shocks

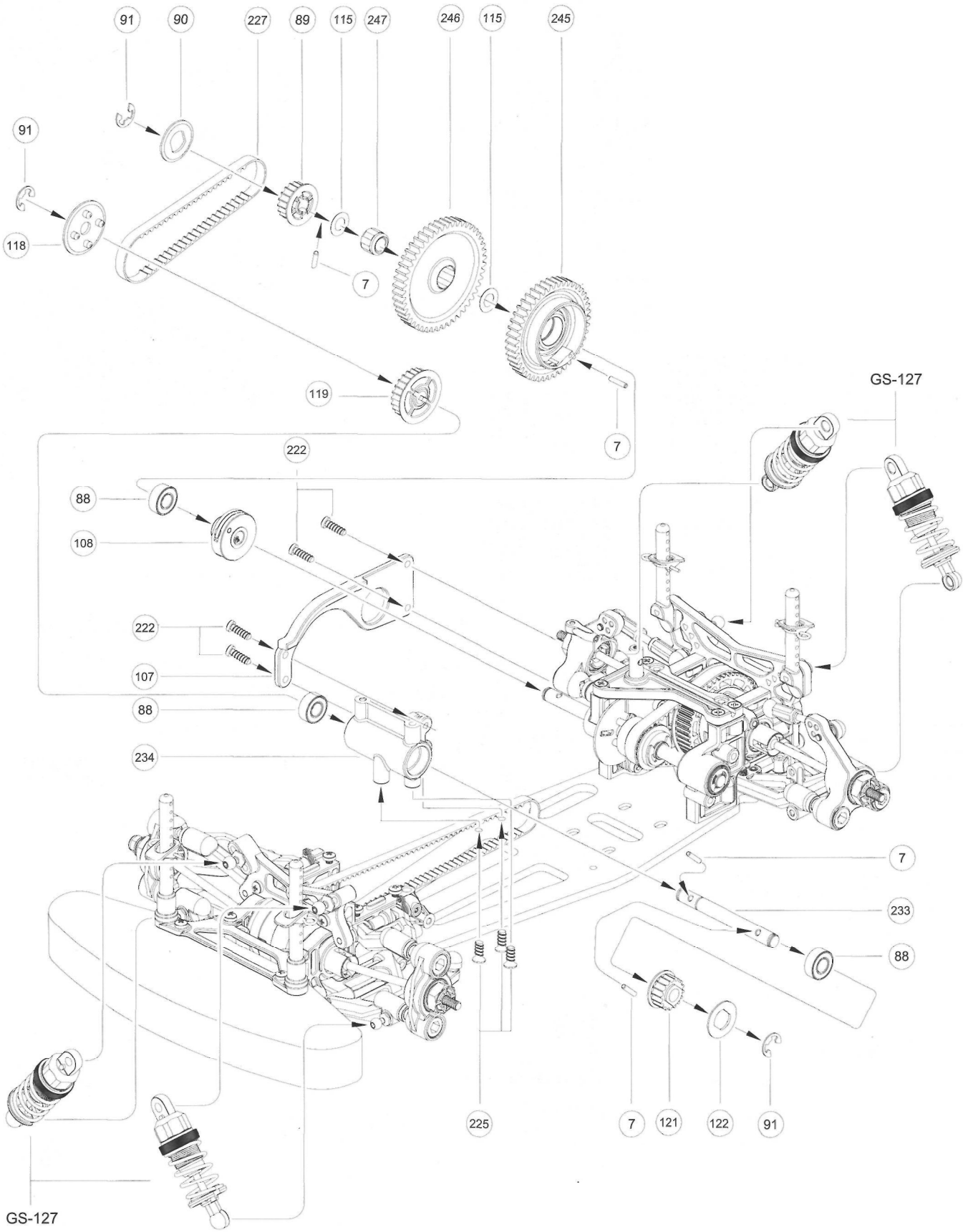

9. Radio Tray & Fuel Tank

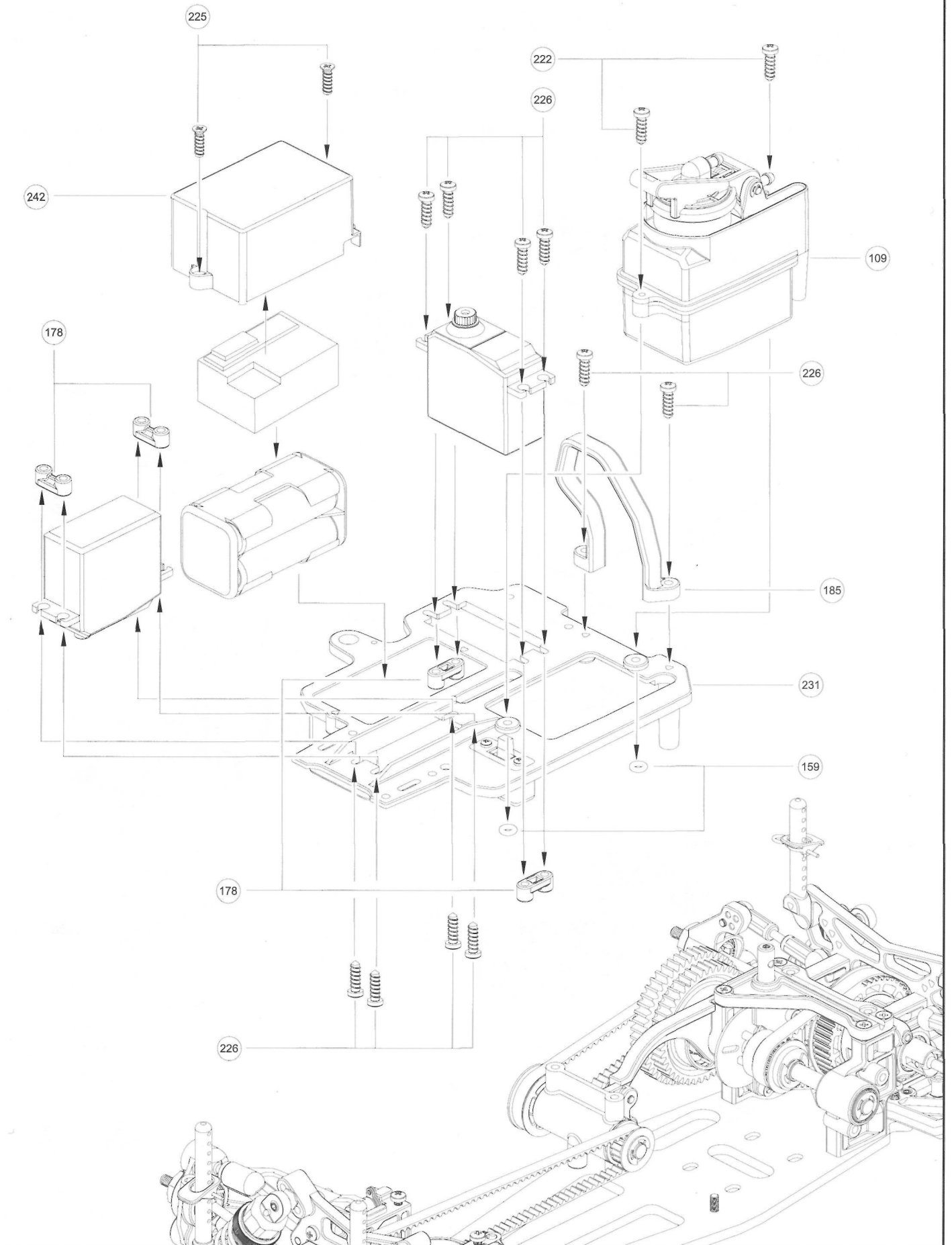

10. Radio Tray & Linkage

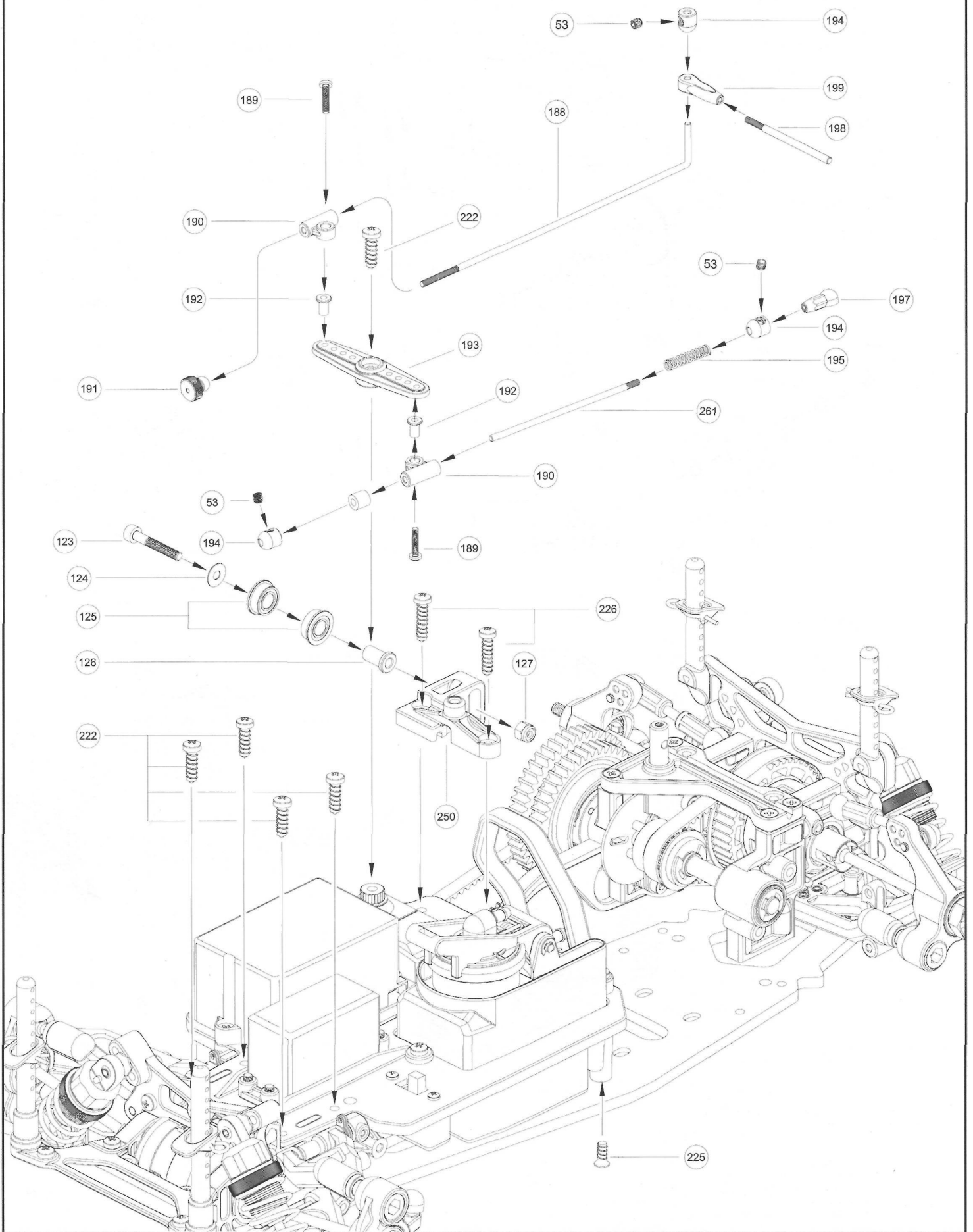

1 1 . Engine & Exhaust System

Note: (201) The air filter dose not come pre-oiled from the factory. Please make sure you properly oil the air filter.

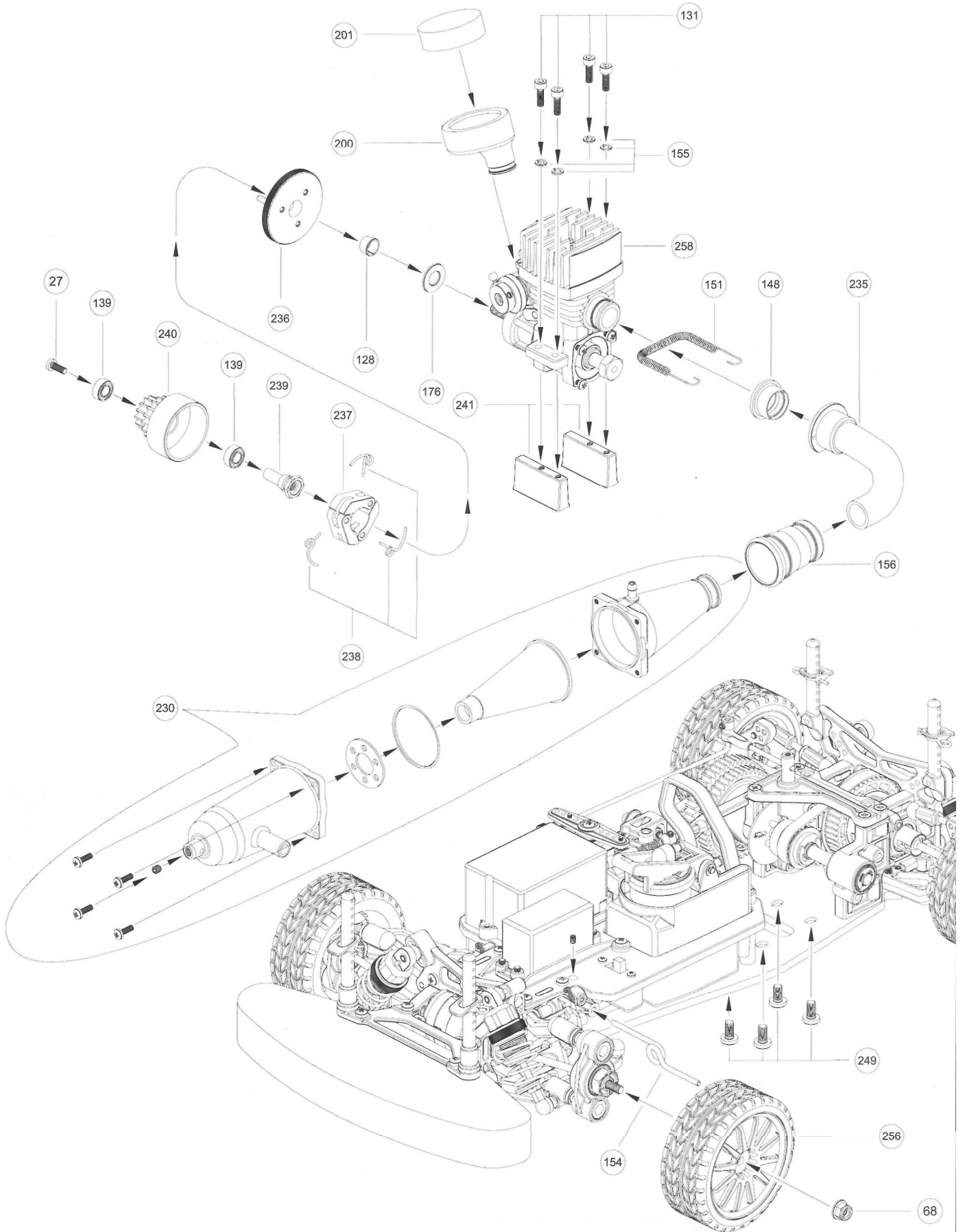

12. Body

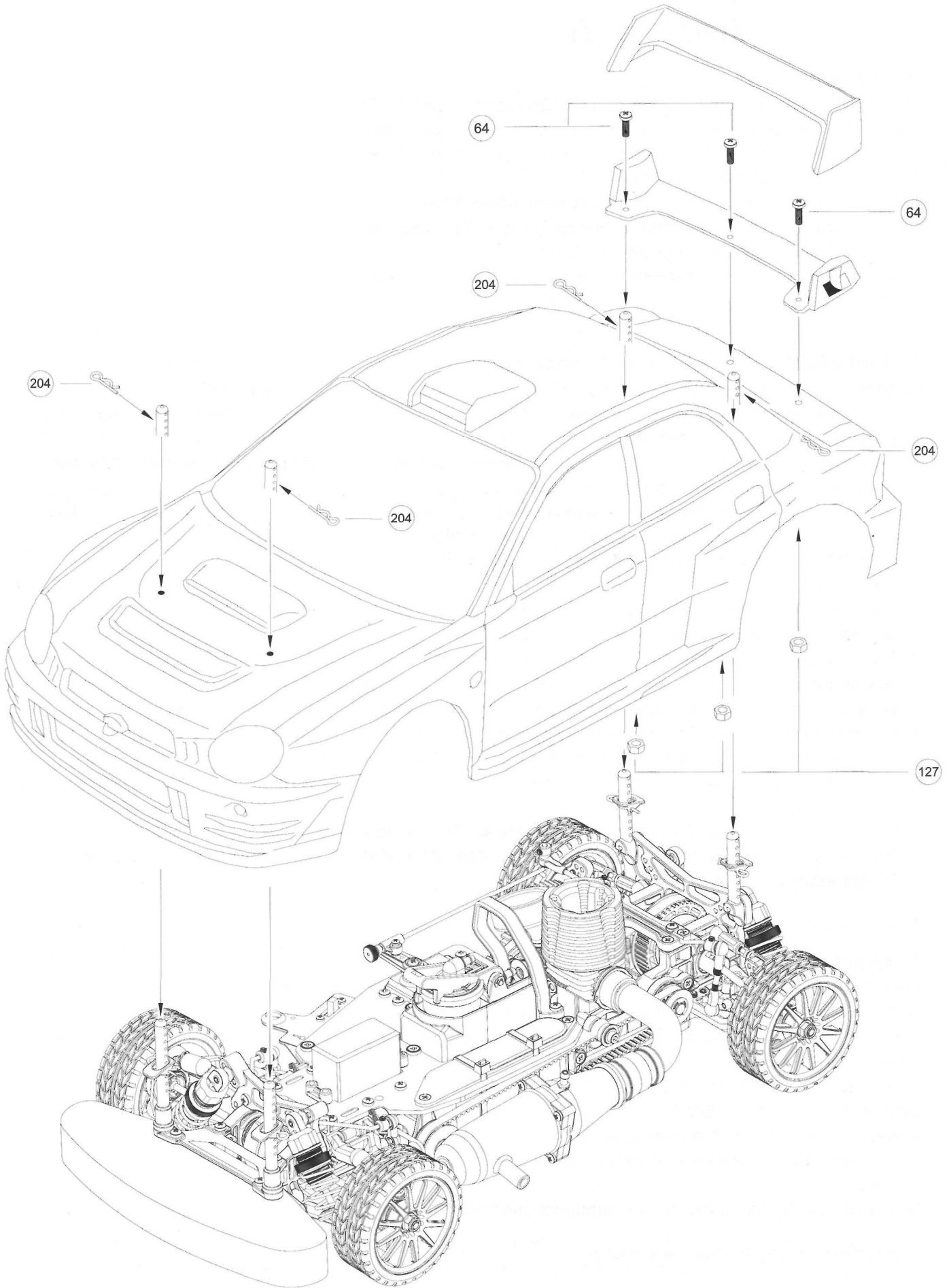

Before You Run Your VISION

About Glow Fuel:

The engines used for the GS Racing nitro **VISION** require glow fuel. To get the proper fuel is very important for long engine life. Improper fuel can cause starting problems, poor performance, and excessive wear on the engines. There are many brands of glow fuels; however, they must meet the following requirements:

1. Use a popular name brand of glow fuel.
2. Try to keep the nitro (nitro methane) between 10% ~ 20%!
3. Do not use any type of airplane or helicopter fuels. The fuels for airplanes and helicopters may not have the necessary oil types and ratios needed for R/C cars.
4. Be careful not to purchase gasoline or kerosene by mistake. Both cannot be used! Also, be very careful when handling glow fuel. It is highly flammable and explosive!

***** About Radio System (Refer to radio manual):***

Read the instructions that come with your radio. You should understand the operation of your transmitter. Place eight AA batteries in the transmitter, and transmitter, and place four AA batteries in the battery holder as receiver pack. It is important that all the batteries are fresh or fully charged.

Always check the path and the condition of the battery pack wires as well as the switch wires. A broken wire can cause a short circuit and lead to a loss of control.

Always turn your transmitter on first and off last. If you start your car before turning on your transmitter, you will lose control of the car and cause damage to property and your car.

Test the following radio functions without the engine running:

1. Turn on the transmitter.
2. Turn on the car receiver battery pack switch. Both the steering and throttle servos should move to their respective neutral settings.
3. Turn the steering wheel on the transmitter left and right. The front wheels should turn left and right (when viewed from behind). Use the steering trim adjustment to set the neutral (wheels pointing straight ahead) setting on your car. If your servos are slow, check your batteries.
4. Pull the throttle trigger. The carburetor should open on the engine.
5. Push the throttle trigger open and forward. This will activate the brakes.
6. Use the throttle trim adjustment to set the neutral (carburetor closed, brakes starting to engage) setting on your car.
7. Hold the throttle open and roll the car on the ground. The car should roll freely. While it is still rolling, push on the brakes. The car should come to an immediate stop. If these steps do not produce these results refer to the linkage assembly setup in this manual.

**** Refer to your radio instruction manual.**

***** About the Carburetor:***

Let's check the carburetor linkage before you fire up the engine for the first time.

Pull off the air filter. Turn the transmitter on first, followed by the car.

With your finger off the throttle, which is the neutral position, the throttle should be almost closed, with an opening about 0.7 ~ 1mm.

Pull the throttle wide open and look into the carburetor and see if it's opening all the way up. If you don't see the gap, adjust the "Throttle End Point Adjustment" on your transmitter according to the radio manual, or adjust the linkage shown earlier in this manual to achieve full throttle. When everything is adjusted OK, turn the switch off in your car first, followed by your transmitter. You must remember to turn off your car's electronics overtime in this order.

Now, place the air filter back on your carburetor and fasten it with a tie wrap.

**** Refer to your engine instruction manual.**

Checklist before Running

- Ensure all screws are securely tightened.
- Ensure all moving parts move without binding.
- l Install an oiled air filter. Ensure it is clean and not clogged.
- Ensure the fuel line is leak proof, with no cracks. Ensure it is not clogged.
- Ensure the muffler and exhaust are damage-free.
- Ensure the radio batteries are fresh. Ensure they are securely installed.
- Ensure servos and linkages move without binding.
- Ensure the area of operation is safe.
- Ensure no one is on your frequency.

*****Break-in the Engine***

The break-in step is required for brand new engines. If you fail to properly break-in an engine, you will cause permanent and premature damage to your engine. Engine operation and tuning will become difficult and engine life will be shortened. During the break-in period, do not operate the engine at high rpm's!

Please check the following steps for breaking-in your engine.

1. Start the engine using either a Starter Box or Pull Starter.
2. Fill the tank with the proper nitro fuel. For breaking in purposes, fill the tank completely. For tuning purposes, fill the tank half way. The GSV12RSX engine supplied with your **Vision RTR** has factory preset needle settings.
3. Place the car on top of a stand with the wheels off the ground.
4. Here' s a tip to aid in starting the engine. If it is a cold start (engine and pipe are both at ambient temperature), place your finger (or other object) over the exhaust stinger outlet and pull the starter cord 3 or 4 times. This will force fuel into the engine and help start it quicker. The engine should now start within the first 3 or 4 pulls. If it is a hot start (engine and pipe at operating temperature), simply pull the throttle open about 10% and pull the starter cord. If engine does not start within 4-5 pulls, you may need to let it cool down first. You can spray a small amount of alcohol directly on the carb and engine head. This usually helps restart the engine.
5. Slowly raise the throttle and check to make sure the tires spin and the brakes work. (If the tires do not spin at all, or they spin poorly, refer to the assembly instruction manual.)
6. Break-in the engine. Allow the engine to idle for 5 minutes, then shut down and allow it to cool. Repeat this procedure for an entire tank of fuel. After the first tank, begin to run the car at low speeds. After each tank of fuel is consumed, tighten the main needle valve 10° ~ 20°. Monitor engine temperature during this process. You want to slowly bring the temperature of the motor up to around 200F. Make sure there is plenty of smoke coming out of the exhaust. The factory settings for the idle and bottom end screw should be fine during this time. You may need to raise or lower the idle depending on many variables, but the bottom end screw should be left alone. Idle should be just high enough to prevent the engine from shutting off.
7. Run the engine a total of 5 tanks of fuel to complete the brake-in.

** Refer to your engine instruction manual.

****Engine Adjustment**

Adjust in the order 1, 2, and 3 after completing the break-in.

1. Main Needle Adjustment (Top End R.P.M. Adjustment)

- Start the engine and run your car until motor reaches operating temperature. Always make Main Needle Adjustments with the fuel tank half full.
NEVER MAKE NEEDLE VALVE ADJUSTMENTS UNTIL MOTOR REACHES OPERATING TEMPERATURE!
- Monitor the top speed of your car at full throttle. When tightening (leaning) the main needle valve 10°~ 20° degrees, speed increases. As your car reaches top speed, the needle valve setting is optimal.
- Factory setting are very close to actual setting you will use. Depending on fuel, weather, type of plug, etc., actual bottom end setting will likely be within 1 turn in from the factory setting.
- Tightening the main needle valve further will cause a decrease in both engine rpm and exhaust emissions. Running the engine with this setting (too lean) will cause engine damage. Unscrew (richen) the needle valve at once. Note that for normal operation,unscrew the main needle valve 10°~ 20° from the optimal setting position! Normal operating temperature for most motors is between 200F to 250F.

2. Idle Adjustment Screw (Idle R.P.M. Adjustment)

- Set throttle position to neutral (carburetor in closed position.)
 - I. The engine stalls. — Tighten by 1/8 ~ 1/4 turns.
 - II. The car rolls forward or idle is too high. — Unscrew by 1/8 - 1/4 turns.
- Adjust the idle so the car will not speed off when the throttle is in neutral and the brakes are not applied.

3. Bottom End Adjustment Screw (Low end R.P.M.)

- Allow motor to reach maximum rev's for 1 ~ 2 seconds then set throttle position to neutral (carburetor in closed position.)
 - I. Idle stays high for 5 ~ 6 seconds, then drops to normal idle, then shuts off.
— Tighten by 1/8 ~ 1/4 turns (bottom end too rich.)
 - II. Idle drops to normal then rises.
— Loosen by 1/8 ~ 1/4 turns (bottom end too lean)
- Adjust bottom end so that engine idles smooth for at least 30 seconds. Upon applying throttle, the engine should emit a good amount of exhaust smoke. After applying full throttle and returning to the neutral position, engine should return to normal idle within 1 ~ 3 seconds.

IMPORTANT!

NEVER run your nitro powered R/C cars without an oiled air filter on. The air filter is essential for keeping dirt out of the engine. The air filter should be inspected carefully every time you refuel. When the air filter starts to get dirty, do the following steps:

1. Clean the foam out with fuel or alcohol. Do this by pouring a small amount in a small can and kneading the filter in it. When the foam is clean, dispose of the fuel or alcohol properly.
2. Squeeze out the fuel with a paper towel until it's dry.
3. Apply the air filter oil around the filter, put the filter in a plastic bag and knead it until the filter is saturated, but not soaked.

**** Refer to your engine instruction manual!**

****Engine Adjustment**

STANDARD

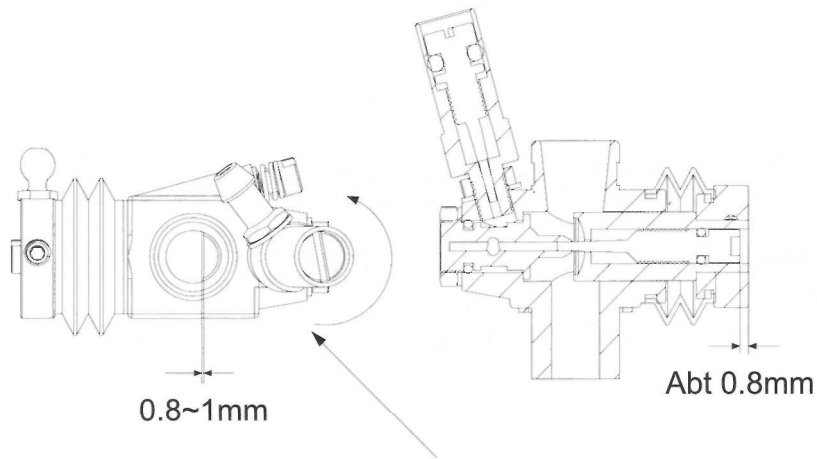

**2 and 1/2 turns
CCW from closed**

Shutting off the Engine:

There are several ways to shut the engine off. Here are some suggestions. Please exercise caution when attempting to shut the engine off to avoid any bodily harm.

1. You can simply allow the engine to run until there is no more fuel in the tank. If your engine is tuned properly, you will notice a slight rise in idle just before the engine shuts off. If the engine idles erratically well before it shuts off, your engine settings may be lean.
2. You may place an object (a rag, the sole of your shoe, etc.) over the tip of the exhaust stinger. By covering the exhaust stinger, the engine will shut off immediately. Do not use your bare fingers as you risk injury.
3. You may bump the flywheel with an object (a rag, the sole of your shoe, the handle of a screwdriver, etc.). Do not use your bare fingers as you risk injury.
4. You may press your finger (or other blunt, clean object) over and into the air filter. This method is recommended only in case of emergency. Pressing into the air filter may force dirt into the engine. Contact with the engine or carburetor may cause burns.
5. You may pinch the fuel line (the tubing that goes from the tank to the engine) with a pair of needle nose pliers until the engine shuts off. Use caution as to not cut or damage the fuel line. If your engine is tuned properly, you will notice a slight rise in idle just before the engine shuts off. If the engine idles erratically well before it shuts off, your engine settings may be lean.

Maintenance

- Before storing your car away, draw out any fuel from the fuel tank.
- Next, restart the engine to combust remaining fuel. Leaving fuel inside the engine will make engine starting difficult and may cause rust to form. Apply after-run oil to the engine.
- Wipe off dirt and oil.
- Check all parts for loose screws.
- Disconnect the receiver batteries.

Operating Your Model Safely

1. Operate the model in open areas with no people around! Do not operate it:
 - on public roads!
 - in places where children and people are present!
 - in residential districts and parks!
 - indoors and in confined areas!

Non-observance may account for personal injury and property damage!
2. Always check the batteries in the transmitter and the battery pack for the receiver!
When the batteries get weak, the transmission and reception of the radio decrease. You may lose control of your model when operating it under such conditions. This may lead to accidents!
3. Keep in mind that people around you might also be operating a radio control model!
Never share the same frequency with somebody else at the same time! Signals will be mixed and you will lose control of your model. This may lead to accidents!
4. Always use approved ground frequencies!
5. When the model is behaving strangely...!
Immediately stop the model and check for the cause. As long as the problem is unclear, do not operate the car! This may lead to further trouble and unforeseen accidents!
6. Handle fuel outdoors only!
Fuel vapors and exhausts are toxic!
7. Do not put fingers or any objects inside rotating and moving parts!
Parts rotate/move at high speeds, you may be seriously injured!
8. After using, do not touch equipment on the model such as the engine and muffler, because they generate high temperatures!

You may cause severe burns to yourself by touching them!
9. Use only glow fuel for this radio control model!
10. Fuel is highly flammable and explosive!
 - Never use fuel indoors or in places with open fires and sources of heat!
 - Store fuel in cool, dry and dark places. Keep out of children's reach! Shut the cap tightly!
 - Do not dispose of empty fuel cans into a fire! There is danger of explosion.
11. Do not swallow fuel. Do not allow for contact to eyes, nose, face and ears!
If fuel is swallowed, induce vomiting. If fuel gets into eyes, rinse them with water and seek medical help.

VISION RTR Key No. / Parts No. List

Key No.	Kit /Part Name	Q'ty in Use	Part No.	Description
1	Differential Outdrive	4	GS-VS1304	Differential Outdrive (2)
2	10x15mm Ball Bearing	12	GS-690010	10x15mm Ball Bearing (4)
3	M2.6x6 FH Screw	4	GS-620016	M2.6x6FH Screw (10)
4	Front Drive Belt Pulley- 27T	1	GS-VS1305	Drive Belt Pulley Set
5	Differential Gear Case-A	2	GS-VS1301	Differential Gear Case Set
6	P6 O-ring	4	GS-ST067	P6 O-ring
7	2x10mm Pin	12	GS-602013	2x10mm Pin (10)
8	Differential Bevel Gear-B	4	GS-VS1302	Differential Bevel Gear Set
9	Differential Bevel Gear Shaft	4	GS-VS1302	Differential Bevel Gear Set
10	Differential Bevel Gear-A	8	GS-VS1302	Differential Bevel Gear Set
11	M2.6x10FH Screw	8	GS-620018	M2.6x10FH Screw (10)
12	Differential Gear Case-B	2	GS-VS1301	Differential Gear Case
13	Differential Gear Case Gasket	2	GS-VS1303	Differential Gear Case Gasket (3)
14	Rear Drive Belt Pulley - 45T	1	GS-VS1305	Drive Belt Pulley Set
15	5mm Ball Cup (Long)	4	GS-900011	5mm Ball Cup (Long) (10)
17A	Servo Saver Adapter-KO/Sanwa	1	GS-900008BK	Servo Saver/Black
17B	Servo Horn Adapter-KO/Sanwa	1	GS-900007BK	Servo Horn/Black
18A	Servo Saver Adapter-JR	1	GS-900008BK	Servo Saver/Black
18B	Servo Horn Adapter-JR	1	GS-900007BK	Servo Horn/Black
19A	Servo Saver Adapter-F	1	GS-900008BK	Servo Saver/Black
19B	Servo Horn Adapter-F	1	GS-900007BK	Servo Horn/Black
20A	Servo Saver Adapter-H	1	GS-900008BK	Servo Saver/Black
20B	Servo Horn Adapter-H	1	GS-900007BK	Servo Horn/Black
21	Servo Saver/Black	1	GS-900008BK	Servo Saver/Black
22	2-Speed Lever Cam	1	GS-VS1324A	2-Speed Repair Pack
23	2-Speed Lever Cam Spring	1	GS-VS1324A	2-Speed Repair Pack
24	5mm Ball Stud (Short)	4	GS-900016	5mm Ball Stud (Short) (10)
25	3.175mm Ball for 2-Speed	1	GS-VS1324A	2-Speed Repair Pack
28	M3 Flanged Nut	2	GS-603010	M3 Flanged Nut (10)
29	M3x10 Set Screw	8	GS-610005	M3x10 Set Screw (10)
30	Front Bulkhead-R	1	GS-VS1005	Front Bulkhead-R
31	Bulkhead Bearing Collar	4	GS-VS1008	Bulkhead Bearing Collar
32	Front Bulkhead-L	1	GS-VS1004	Front Bulkhead-L
36	Front Upper Suspension Arm-L	1	GS-VS1012	Front Upper Suspension Arm-L
37	Front Lower Suspension Arm-L	1	GS-VS1013	Front Lower Suspension Arm-L
38	Front Down/Up Stop Arm	2	GS-VS1024	Front Down/Up Stop Arm
39	5mm Ball Stud (Long)	8	GS-900017	5mm Ball Stud (Long) (10)
43	Steering Knuckle-L	1	GS-VS1020	Steering Knuckle-L
44	Steering Knuckle-R	1	GS-VS1021	Steering Knuckle-R
45	Front Upper Suspension Arm-R	1	GS-VS1014	Front Upper Suspension Arm-R
46	Front Lower Suspension Arm-R	1	GS-VS1015	Front Lower Suspension Arm-R
47	8mm Pivot Ball	8	GS-VS1027	8mm Pivot Ball (42x4, 47x4)
48	8mm Pivot Cup	8	GS-VS1028	8mm Pivot Ball Nut
49	8mm Pivot Nut	8	GS-VS1028	8mm Pivot Ball Nut
53	M3x3 Set Screw	3	GS-610000	M3x3 Set Screw (10)
54	Front Lower Suspension Hinge Pin	2	GS-VS1018	Front Lower Suspension Hinge Pin (2)

VISION RTR Key No. / Parts No. List

Key No.	Kit/Part Name	Qty in Use	Part No.	Description
55	Front Upper Suspension Hinge Pin	2	GS-VS1017	Front Upper Suspension Hinge Pin (2)
56	M4x6 Set Screw	1	GS-610022	M4x6 Set Screw (10)
57	5.8mm Ball Stud (Short)	4	GS-900018	5.8mm Ball Stud (Short) (10)
59	Front Shock Tower	1	GS-VS1009	Front Shock Tower
62	Rod-25mm	2	GS-250174	Rod-25mm (2)
64	M3x6 BH Screw	2	GS-640020	M3x6BH Screw (10)
68	M4 Nylon Lock Nut	4	GS-603021	M4 Nylon Lock Nut (10)
69	Caster Clip- 2mm (2)	2	GS-VS1025	Caster Clip Set
70	Caster Clip-1 mm (4)	2	GS-VS1025	Caster Clip Set
71	Front Bumper	1	GS-VS1001	Front Bumper Set
72	Front Body Mount Post	2	GS-VS1011	Body Mount
73	Front Bumper Supports	1	GS-VS1001	Front Bumper Set
74	Foam Bumper	1	GS-VS1002	Urethane Bumper
75	Brake Cam	1	GS-VS1327	Brake Cam
76	Rear Bulkhead-R	1	GS-VS1007	Rear Bulkhead-R
77	Brake Disc	1	GS-VS1325	Brake Set
78	Brake Caliper	2	GS-VS1325	Brake Set
79	Brake Pad	2	GS-VS1326	Brake Pad (6)
82	Brake Disc Pulley Mount	1	GS-VS1328	Brake Disc Pulley Mount
83	M4x4 Set Screw	2	GS-610020	M4x4 Set Screw (10)
84	E-clip 7mm	1	GS-600014	E-clip 7mm (10)
85	Rear Drive Belt Pulley -20T	1	GS-VS1305	Drive Belt Pulley Set
87	Brake Bracket	1	GS-VS1207	Brake Bracket
88	6x13mm Ball Bearing	4	GS-690011	6x13mm Ball Bearing (2)
89	Rear/Side Drive Belt Pulley-18T	1	GS-VS1305	Drive Belt Pulley Set
90	Rear/Side Drive Belt Pulley Flange-18T	1	GS-VS1305	Drive Belt Pulley Set
91	E-clip 5mm	3	GS-600012	E-clip 5mm (10)
92	Rear Bulkhead-L	1	GS-VS1006	Rear Bulkhead-L
93	Rear Belt 60 S3M-186W 6mm	1	GS-VS1310	Rear Belt
94	5.8mm Ball Stud (Short) (Vision)	4	GS-900032	5.8mm Ball Stud (Short) (Vision) (10)
95	Rear Upright-R	1	GS-VS1023	Rear Upright-R
96	Rear Upright-L	1	GS-VS1022	Rear Upright-L
97	Rear Lower Suspension Arm	2	GS-VS1016	Rear Lower Suspension Arm
101	5.8mm Ball Cup (M)	4	GS-900014	5.8mm Ball Cup (M) (10)
102	Rear Lower Suspension Hinge Pin	2	GS-VS1019	Rear Lower Suspension Hinge Pin (2)
103	Rear Plate	1	GS-VS1003	Rear Plate
107	Reinforcement Plate-R	1	GS-VS1214	Reinforcement Plate-R
108	2-Speed	1	GS-VS1324	2-Speed
109	Fuel Tank 75cc	1	GS-VS1208	Fuel Tank 75cc
115	6x11x0.2t Shim	2	GS-200031	6x11x0.2t Shim (10)
118	Drive Belt Pulley Flange-24T	1	GS-VS1305	Drive Belt Pulley Set
119	Drive Belt Pulley -24T	1	GS-VS1305	Drive Belt Pulley Set
121	Drive Belt Pulley-16T	1	GS-VS1305	Drive Belt Pulley Set
122	Drive Belt Pulley Flange-16T	1	GS-VS1305	Drive Belt Pulley Set
124	3x8x0.5t Washer	1	GS-VS1311	Drive Belt Tensioner
125	5x10mm Flanged Ball Bearing	2	GS-690006	5x10mm Flanged Ball Bearing (2)
126	Drive Belt Tensioner Post	1	GS-VS1311	Drive Belt Tensioner

VISION RTR Key No. /Parts No. List

<i>Key No.</i>	<i>Kit/Part Name</i>	<i>Q'tyin Use</i>	<i>Part No.</i>	<i>Description</i>
127	M3 Lock Nut	3	GS-603007	M3 Lock Nut (10)
128	Tapered Collet-7mm	1	GS-VS1426	Tapered Collet-7mm
131	M3x8 Cap Screw	4	GS-611021	M3x8 Cap Screw (10)
139	5x10mm Ball Bearing	2	GS-690001	5x10mm Ball Bearing (2)
148	.12 Exhaust Gasket (TBL)	1	GS-E12(TBL)	.12 Exhaust Gasket (TBL)
151	Manifold Spring	1	GS-VS1407	Manifold Spring
154	Muffler Holder	1	GS-VS1404	Muffler Holder
155	M3 Spring Washer	4	GS-601005	M3 Spring Washer (10)
156	Exhaust Coupler (Purple)	1	GS-CMS-10(PR)	Exhaust Coupler (Purple)
159	P3, O-ring	14	GS-VS1507	O-ring Set
163	E-clip 2mm	4	GS-600007	E-clip 2mm (10)
164	Shock Piston-B	4	GS-VS1506	Shock Piston
165	Shock Piston-A	4	GS-VS1506	Shock Piston
166	E-clip 2.5mm	4	GS-600008	E-clip 2.5mm (10)
167	Shock Shaft Rod-32mm	4	GS-VS1504	Shock Shaft Rod (2)
170	5.0mm Ball Cup (Medium)	4	GS-900012	5.0mm Ball Cup (Medium) (10)
171	Shock Top	4	GS-VS1505	Shock Top
173	Shock Bladder (Vision Only)	4	GS-340027BL	Shock Bladder (Vision Only)
174	Shock Piston Stopper	4	GS-VS1506	Shock Piston
175	Shock Spring Cup	4	GS-VS1508	Shock Spring Cup
176	7x14x1 mm Washer	1	GS-VS1426	Tapered collet 7mm
178	Servo Mount	4	GS-VS1219	Servo Mount (4)
181	Antenna Tube	1	GS-180001	Antenna Tube And Cap
182	Antenna Cap	1	GS-180001	Antenna Tube And Cap
185	Roll Bar	1	GS-VS1209	Roll Bar
188	Brake Linkage Rod	1	GS-VS1218A	Throttle / Brake Linkage (RTR)
189	M2x10 BH Screw	1	GS-640001	M2x10BH Screw (10)
190	Throttle Linkage Holder	1	GS-VS1218A	Throttle / Brake Linkage (RTR)
191	Brake Adjustment Collar	1	GS-VS1218A	Throttle / Brake Linkage (RTR)
192	Throttle Collar	1	GS-VS1218A	Throttle / Brake Linkage (RTR)
193	Servo Horn	1	GS-900007BK	Servo Horn / Black
194	2mm Linkage Stop	2	GS-250177	2mm Stopper Set (10)
195	Linkage Spring	1	GS-VS1218A	Throttle / Brake Linkage (RTR)
197	Throttle Lever 4.8mm Ball Cup	1	GS-VS1218A	Throttle / Brake Linkage (RTR)
198	Brake Cam Lever	1	GS-VS1218A	Throttle / Brake Linkage (RTR)
199	Brake Cam Lever End	1	GS-VS1218A	Throttle / Brake Linkage (RTR)
200	1/10 Air Filter (Fits 10mm Carb)	1	GS-900030	1/10 Air Filter (Fits 10mm Carb)
201	1/10 Air Filter Foam	1	GS-900030A	1/10 Air Filter Foam (2)
203	Body Supports	4	GS-VS1011	Body Mount Set
204	Body Pin-S	8	GS-600006	Body Pin-S (10)
205	Rear Nylon Shock Stay	1	GS-VS1010	Rear Nylon Shock Stay
207	Rear Body Mount Post	2	GS-VS1011	Body Mount Set
209	Shock Spring-1.5mm	4	GS-VS1511	Shock Spring-1.5mm
210	Fuel Filter	1	GS-100105	Fuel Filter
221	M3x14BH/ST Screw	2	GS-670026	M3x14BH/ST Screw(10)
222	M3x10BH/ST Screw	24	GS-670023	M3x10BH/ST Screw(10)
223	Drive Shaft (SPORT.RTR)	4	GS-VS1313	Drive Shaft (SPORT.RTR) (2)

VISION RTR Key No. / Parts No. List

Key No.	Kit/Part Name	Q'ty in Use	Part No.	Description
224	Wheel Axle (SPORT.RTR)	4	GS-VS1314	Wheel Axle (SPORT.RTR) (2)
225	M3x10FH/ST Screw	27	GS-650024	M3x10FH/ST Screw(10)
226	M3x12BH/ST Screw	12	GS-670024	M3x12BH/ST Screw(10)
227	Middle Belt (RTR)	1	GS-VS1309	Middle Belt (RTR)
228	Nylon Wheel Hub	4	GS-VS1316	Nylon Wheel Hub (4)
229	Camber Angle Collar 2.5mm-RTR	6	GS-VS1026A	Camber Angle Collar Set-RTR
230	Muffler (RTR)	1	GS-VS1403	Muffler (RTR)
231	Radio Tray (RTR)	1	GS-VS1206	Radio Tray (RTR)
232	Main Chassis (RTR)	1	GS-VS1203	Main Chassis (RTR)
233	Middle Shaft (RTR)	1	GS-VS1320	Middle Shaft (RTR)
234	Middle Shaft Housing (RTR)	1	GS-VS1212	Middle Shaft Housing (RTR)
235	Manifold-S (RTR)	1	GS-VS1406	Manifold-S (RTR)
236	Flywheel 36mm (SPORT.RTR)	1	GS-VS1423	Flywheel 36mm (SPORT.RTR)
237	Clutch Shoe	3	GS-ST004	Clutch Shoe (3)
238	Clutch Shoe Spring	3	GS-ST003	Clutch Shoe Spring (3)
239	Pilot Shaft Nut (SPORT.RTR)	1	GS-VS1424	Pilot Shaft Nut (SPORT.RTR)
240	Clutch Bell /1418T (RTR)	1	GS-VS2418	Clutch Bell /1418T (RTR)
241	Engine Mount (SPORT.RTR)	2	GS-VS1402	Engine Mount (SPORT.RTR)
242	Radio Receiver Box (RTR)	1	GS-VS1217	Radio Receiver Box (RTR)
243	Camber Angle Collar 3mm-RTR	2	GS-VS1026A	Camber Angle Collar Set-RTR
244	Front Belt (RTR)	1	GS-VS1308	Front Belt (RTR)
245	2nd Spur Gear-44T (RTR)	1	GS-VS2144	2nd Spur Gear-44T (RTR)
246	1st Spur Gear-48T (RTR)	1	GS-VS2148	1st Spur Gear-48T (RTR)
247	One-way Bearing (RTR)	1	GS-690016	One-way Bearing (RTR)
248	2-Speed Lay Shaft (RTR)	1	GS-VS1318	2-Speed Lay Shaft (RTR)
249	M4x8 BH Screw	4	GS-640040	M4x8BH Screw (10)
250	Drive Belt Tensioner Holder (RTR)	1	GS-VS1311A	Drive Belt Tensioner Holder (RTR)
251	Nylon Shock Cylinder (SPORT.RTR)	4	GS-VS1501	Nylon Shock Cylinder (SPORT.RTR)
252	Nylon Shock Cylinder O-Ring Stopper (SPORT.RTR)	4	GS-VS1501	Nylon Shock Cylinder (SPORT.RTR)
253	Nylon Shock Spring Adjust Nut (RTR.SPORT)	4	GS-VS1518	Nylon Shock Spring Adjust Nut (RTR.SPORT)
254	Nylon Shock Cylinder Cap (RTR.SPORT)	4	GS-VS1520	Nylon Shock Cylinder Cap (RTR.SPORT)
255	1 /10 VISION S-Body-Painted	1	GS-150002B	1 /10 VISION S-Body-Painted
256	1/10 Touring Car Rubber Tire	4	GS-350003	1/10 Touring Car Rubber Tire
257	1/10 Touring Car Rubber Tire Inner Foam	4	GS-350003	1/10 Touring Car Rubber Tire
258	V12RSX Engine	1	GS-890060	V12RSX Engine
259	1/10 Rubber Tire Wheel-5SP / White	4	GS-100108A-WH	1/10 Rubber Tire Wheel-5SP / White
261	Throttle Linkage Rod (55mm)	1	GS-VS1218A	Throttle / Brake Linkage (RTR)
262	Vision RTR Instruction Manual / S-Body	1	GS-VS3013	Vision RTR Instruction Manual / S-Body
263	Vision RTR Instruction Manual / Impreza	1	GS-VS3014	Vision RTR Instruction Manual / Impreza
271	Shock Piston-2 holes	4	GS-VS1506	Shock Piston
272	Shock Piston-3 holes	4	GS-VS1506	Shock Piston
279	1/10 VISION IMPREZA Painted	1	GS-150003B	1 /10 VISION IMPREZA Painted
280	1/10 Rubber Tire Wheel-12SP/White	4	GS-100109B-WH	1/10 Rubber Tire Wheel-12SP/White

**** In North, Central, and South America, please convert the " CS-" prefix to "CSC" for all part numbers.**

VISION RTR Key No. / Parts No. List

<i>Item No.</i>	<i>Part Name</i>	<i>Item No.</i>	<i>Part Name</i>
GS-VS1312	Universal Drive Shaft (PRO) (2)	GS-70004	Pure Silicone Shock Oil,250 cps.
GS-VS1315	Aluminium Wheel Hub (5)	GS-70005	Pure Silicone Shock Oil,300 cps.
GS-VS1323	2-Speed 1st Gear Housing Set (RTR)	GS-70006	Pure Silicone Shock Oil,350 cps.
GS-VS1401	Engine Mount (PRO)	GS-70007	Pure Silicone Shock Oil,400 cps.
GS-VS1405	Manifold (PRO / SPORT)	GS-70008	Pure Silicone Shock Oil,450 cps.
GS-VS1408	Power Clutch	GS-70009	Pure Silicone Shock Oil,500 cps.
GS-VS1422	Clutch Bell (SPORT)	GS-70019	Pure Silicone Diff. Oil,1000 cps.
GS-VS1425	SG Pilot Nut (SPORT / RTR)	GS-70021	Pure Silicone Diff. Oil.3000 cps.
GS-VS1601A	Front Anti-Roll Bar-2.0,2.2,2.4mm	GS-70023	Pure Silicone Diff. Oil,5000 cps.
GS-VS1602A	Rear Anti-Roll Bar-2.0,2.2,2.4mm	GS-70025	Pure Silicone Diff. Oil,7000 cps.
GS-VS2014	1st Pinion Gear, 14T	GS-70028	Pure Silicone Diff. Oil,10000 cps.
GS-VS2015	1st Pinion Gear, 15T	GS-70030	Pure Silicone Diff. Oil,30000 cps.
GS-VS2016	1st Pinion Gear, 16T	GS-70032	Pure Silicone Diff. Oil.50000 cps.
GS-VS2017	2nd Pinion Gear, 17T	GS-700105	Pure Silicone Shock Oil.20 wt.
GS-VS2018	2nd Pinion Gear, 18T	GS-700107	Pure Silicone Shock Oil,25 wt.
GS-VS2019	2nd Pinion Gear, 19T	GS-700109	Pure Silicone Shock Oil,30 wt.
GS-VS2043	2nd Spur Gear, 43T	GS-700111	Pure Silicone Shock Oil,35 wt.
GS-VS2044	2nd Spur Gear, 44T	GS-700113	Pure Silicone Shock Oil,40 wt.
GS-VS2045	2nd Spur Gear, 45T	GS-700115	Pure Silicone Shock Oil,45 wt.
GS-VS2046	1st Spur Gear, 46T	GS-700117	Pure Silicone Shock Oil.50 wt.
GS-VS2047	1st Spur Gear, 47T	GS-700119	Pure Silicone Shock Oil,55 wt.
GS-VS2048	1 st Spur Gear, 48T	GS-700121	Pure Silicone Shock Oil,60 wt.
GS-VS2049	1st Spur Gear, 49T	GS-CMS-10PR	Exhaust Coupler (PR)
GS-VS2519	Clutch Bell /1519T (RTR)	GS-CMS-10BL	Exhaust Coupler (BL)
GS-126	1/10 Touring Car High Performance Shock (2)	GS-CMS-10FG	Exhaust Coupler (FG)
GS-VS1522	Shock Spring 1.4mm(Yellow) 1.5mm(Blue) 1.6mm(Pink)	GS-CMS-10FP	Exhaust Coupler (FP)
		GS-CMS-10FR	Exhaust Coupler (FR)
		GS-CMS-10FY	Exhaust Coupler (FY)
		GS-CMS-10GR	Exhaust Coupler (GR)
		GS-CMS-10LB	Exhaust Coupler (LB)
		GS-CMS-10RD	Exhaust Coupler (RD)
		GS-CMS-10TBL	Exhaust Coupler (TBL)
		GS-CMS-10YL	Exhaust Coupler (YL)
		GS-E12TBL	.12 Exhaust Gasket (TBL)
		GS-E12BL	.12 Exhaust Gasket (BL)
		GS-E12FG	.12 Exhaust Gasket (FG)
		GS-E12FO	.12 Exhaust Gasket (FO)
		GS-E12FP	.12 Exhaust Gasket (FP)
		GS-E12FY	.12 Exhaust Gasket (FY)
		GS-E12FR	.12 Exhaust Gasket (FR)
		GS-E12GR	.12 Exhaust Gasket (GR)
		GS-E12LB	.12 Exhaust Gasket (LB)
		GS-E12LOR	.12 Exhaust Gasket (LOR)
		GS-E12PR	.12 Exhaust Gasket (PR)
		GS-E12YL	.12 Exhaust Gasket (YL)

**** In North, Central, and South America, please convert the " GS-" prefix to "GSC" for all part numbers.**

MEMO:

Optional Parts

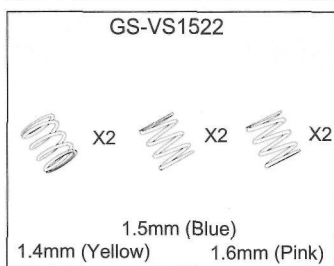
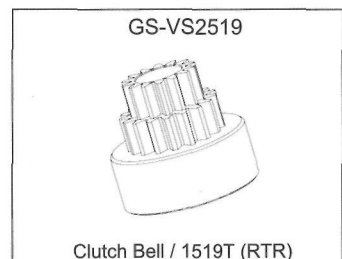
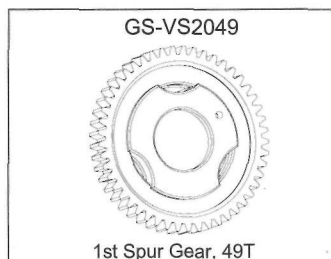
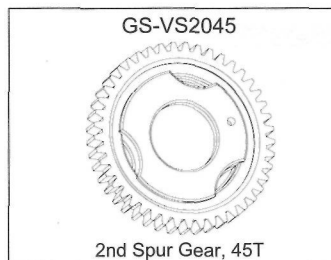
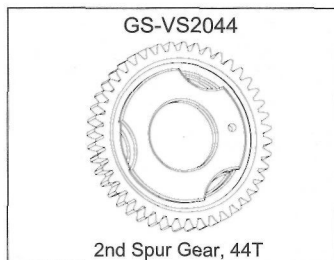
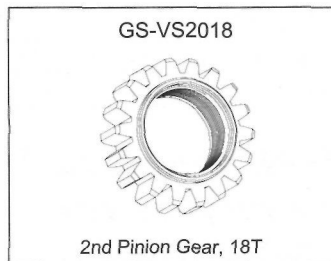
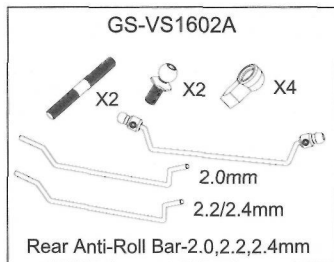
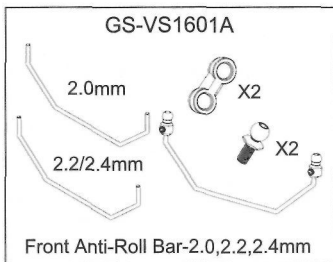
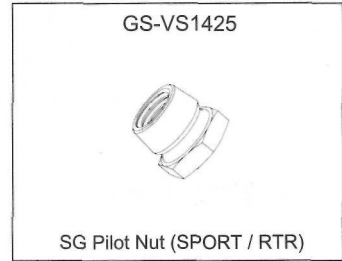
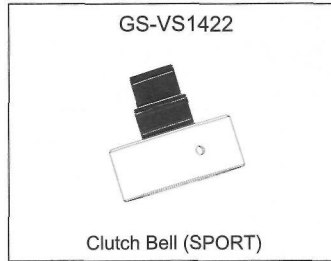
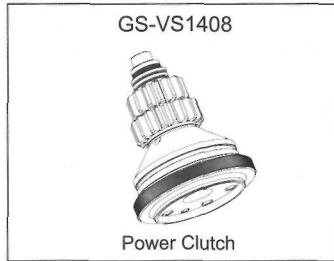
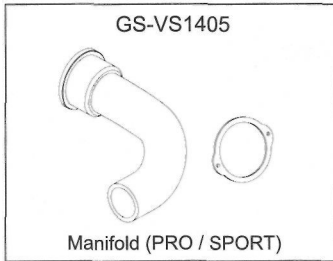
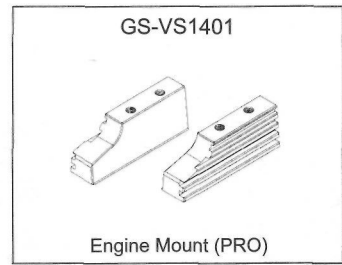
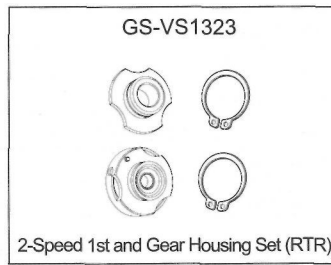
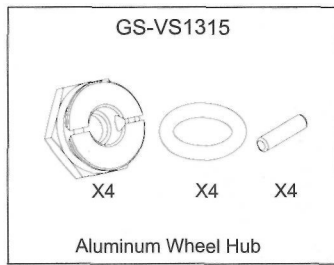
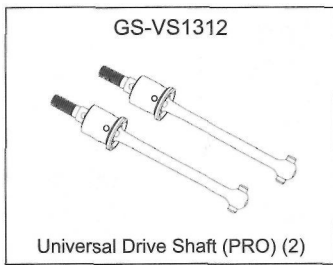

EXPLODED VIEW (1)

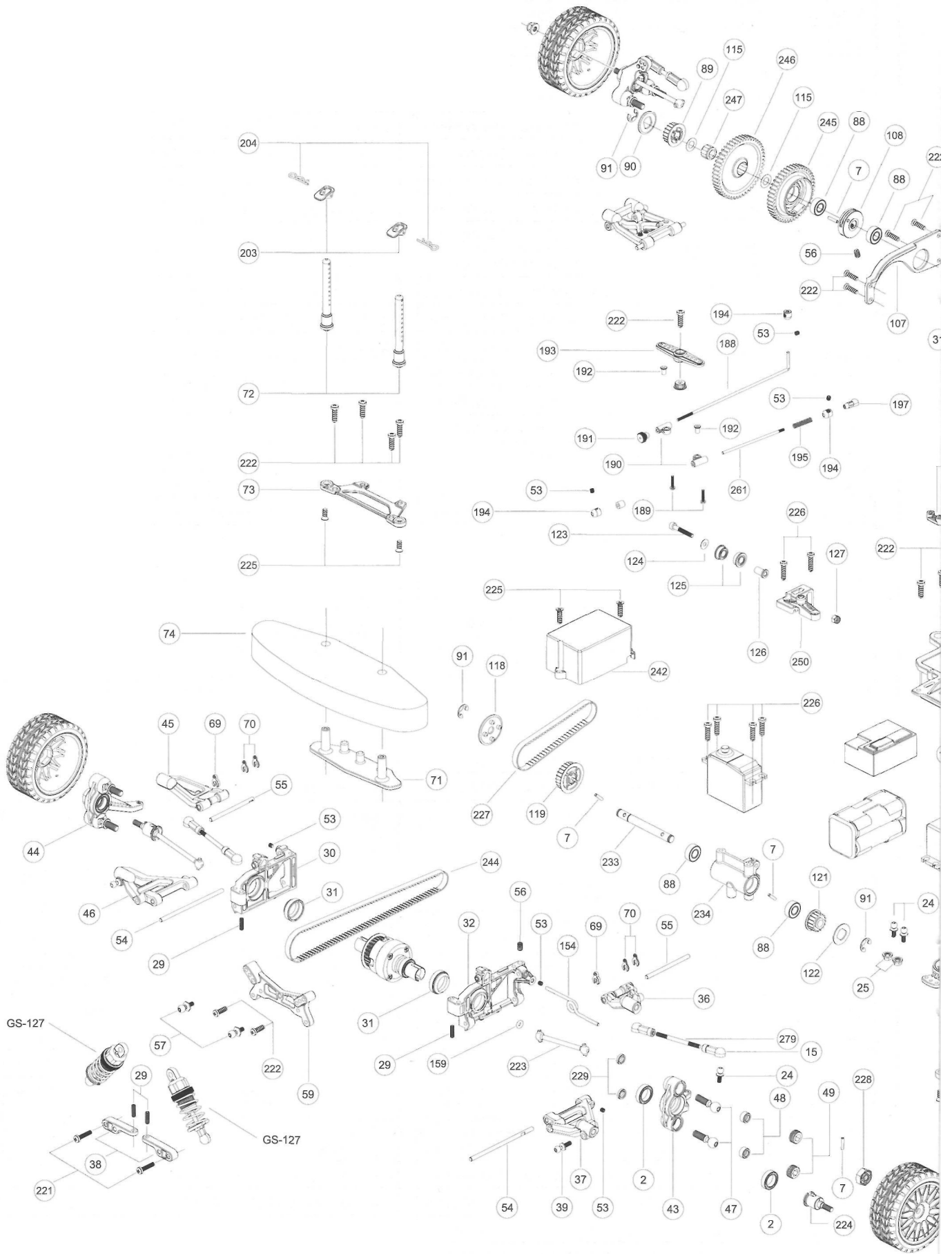

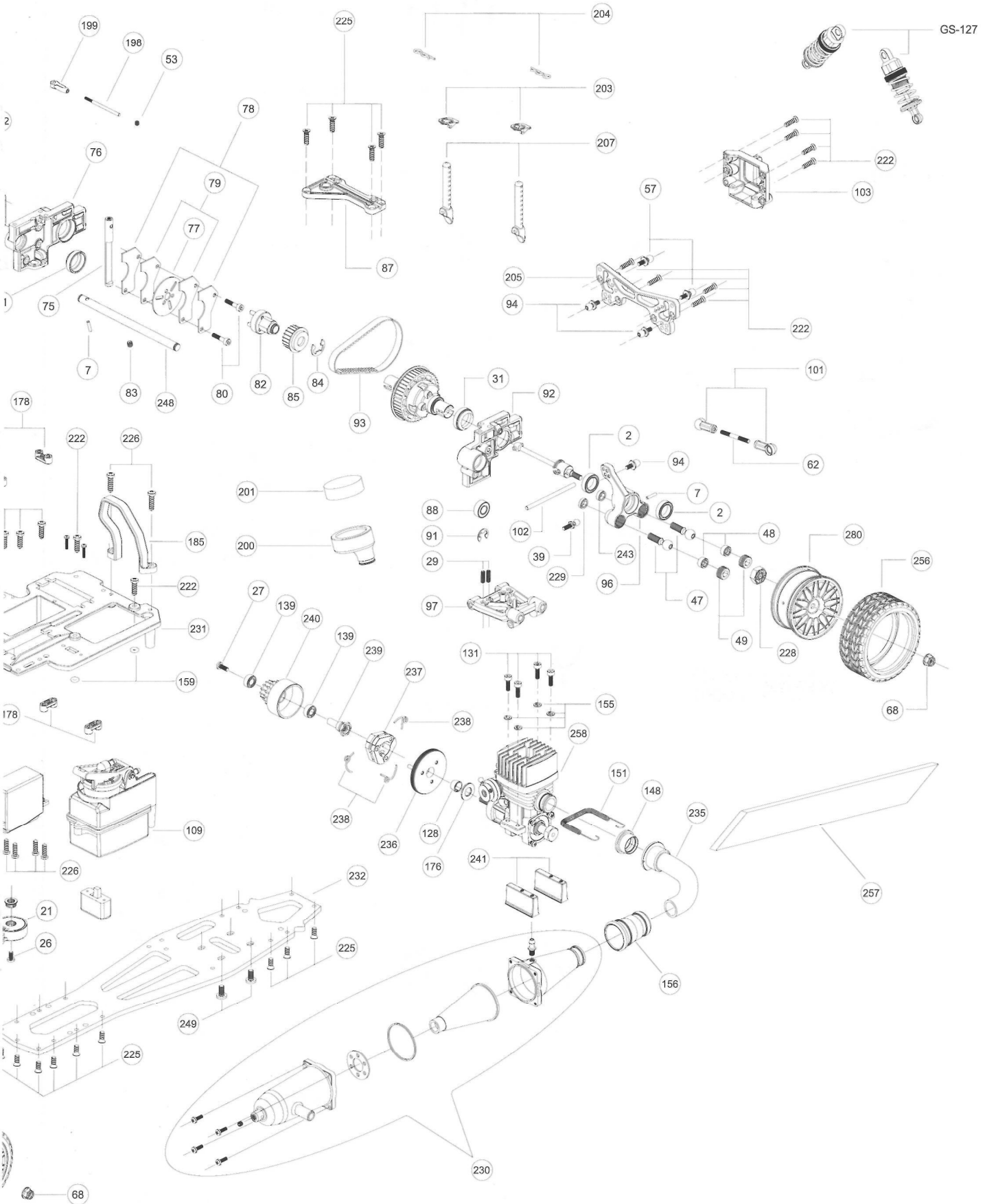

EXPLODED VIEW (2)

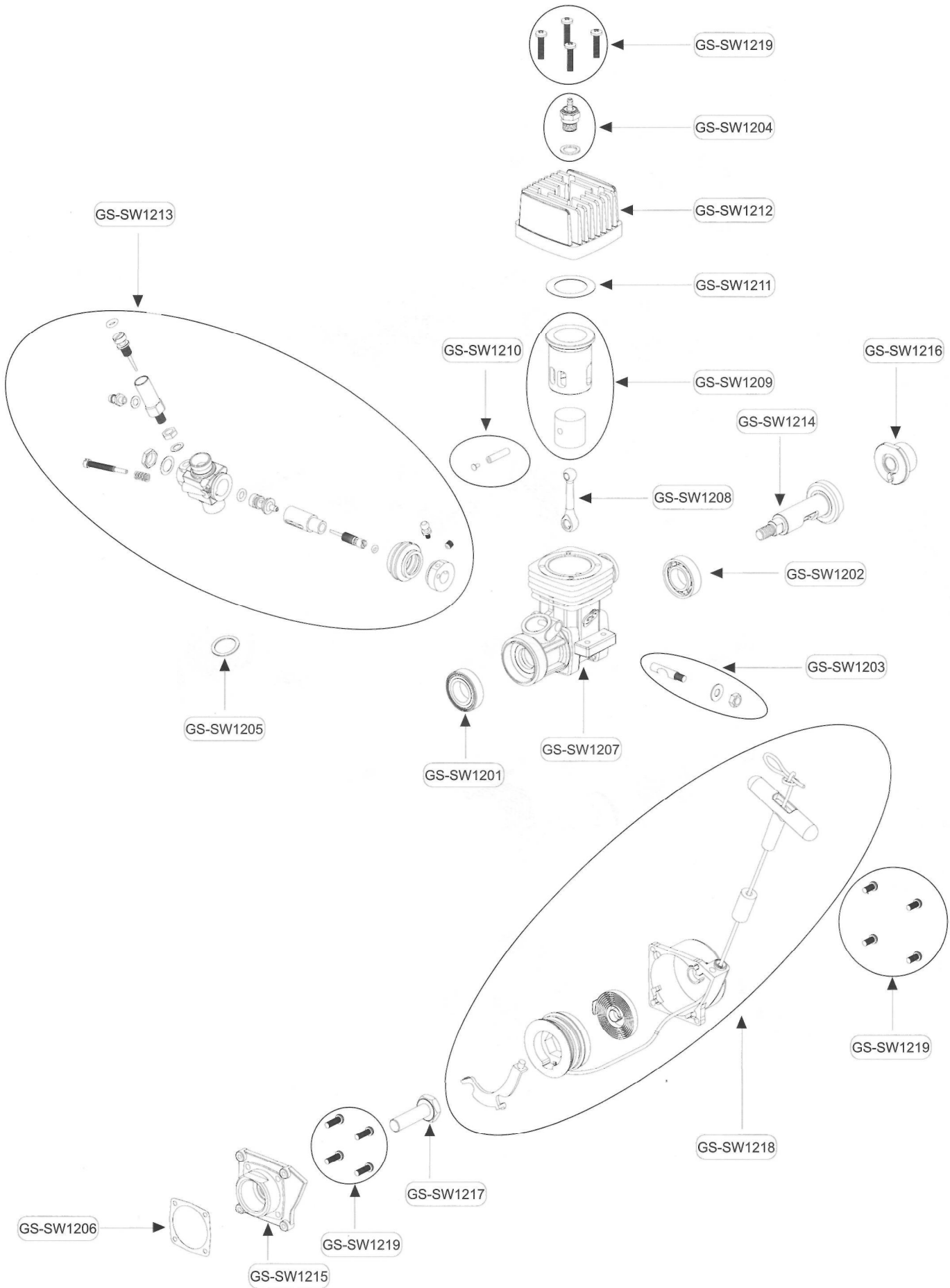

V12RSX Engine Parts List

Part No.	Name of Parts
GS-SW1201	Crank Shaft Bearing (FRONT)
GS-SW1202	Crank Shaft Bearing (REAR)
GS-SW1203	Carburetor Retainer Set
GS-SW1204	Glow Plug Set (w/Gasket)
GS-SW1205	Carburetor Gasket
GS-SW1206	Cover Plate Gasket
GS-SW1207	Crank Case for V12RSX
GS-SW1208	Conrod for V12RSX
GS-SW1209	Piston & Cylinder Set for V12RSX
GS-SW1210	Wrist Pin Set for V12RSX
GS-SW1211	Head Shims for V12RSX
GS-SW1212	Heat Sink Head (Cast Aluminum) for V12RSX
GS-SW1213	5.0mm Slide Carburetor Assembly for V12RSX
GS-SW1214	Crank Shaft for V12RSX
GS-SW1215	Cover Plate for Pull Start
GS-SW1216	One Way Bearing
GS-SW1217	One Way Bearing Shaft
GS-SW1218	Pull Start Assembly (w/o One Way Bearing)
GS-SW1219	Screw Set for V12RSX



**** In North, Central, and South America, please convert the " GS-" prefix to "GSC" for all part numbers.**

MEMO:

VISION RTR Set Up Sheet

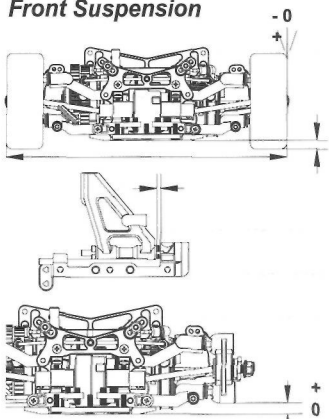

Name <u>Standard</u> Date _____ Track _____	Track Conditions <ul style="list-style-type: none"> · Size: <input type="checkbox"/> Open <input checked="" type="checkbox"/> Med · Tight · Traction: <input checked="" type="checkbox"/> High · Med · Low · Surface: <input checked="" type="checkbox"/> Smooth · Bumpy
--	---

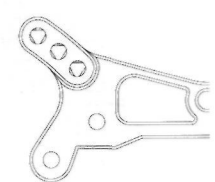
Front Suspension 	<table style="width: 100%; border-collapse: collapse;"> <tr> <td style="width: 15%;">Track width</td> <td style="width: 15%; text-align: center;"><u>198</u></td> <td style="width: 15%;">mm</td> </tr> <tr> <td>Ride height</td> <td style="text-align: center;"><u>5</u></td> <td>mm</td> </tr> <tr> <td>Camber angle</td> <td style="text-align: center;"><u>-1</u></td> <td>degree</td> </tr> <tr> <td>Caster angle</td> <td style="text-align: center;"><u>2.0</u></td> <td>mm</td> </tr> <tr> <td>Toe angle</td> <td style="text-align: center;"><u>0</u></td> <td>mm</td> </tr> </table>	Track width	<u>198</u>	mm	Ride height	<u>5</u>	mm	Camber angle	<u>-1</u>	degree	Caster angle	<u>2.0</u>	mm	Toe angle	<u>0</u>	mm
Track width	<u>198</u>	mm														
Ride height	<u>5</u>	mm														
Camber angle	<u>-1</u>	degree														
Caster angle	<u>2.0</u>	mm														
Toe angle	<u>0</u>	mm														

Front shocks 	<table style="width: 100%; border-collapse: collapse;"> <tr> <td style="width: 15%;">Piston</td> <td style="width: 15%; text-align: center;"><u>1</u></td> </tr> <tr> <td>Oil #</td> <td style="text-align: center;"><u>GS 1000</u> cps.</td> </tr> <tr> <td>Spring</td> <td style="text-align: center;"><u>1.5</u> mm</td> </tr> <tr> <td>Tension</td> <td style="text-align: center;"><u>3.5</u> mm</td> </tr> </table>	Piston	<u>1</u>	Oil #	<u>GS 1000</u> cps.	Spring	<u>1.5</u> mm	Tension	<u>3.5</u> mm
Piston	<u>1</u>								
Oil #	<u>GS 1000</u> cps.								
Spring	<u>1.5</u> mm								
Tension	<u>3.5</u> mm								
Shock position Middle 									

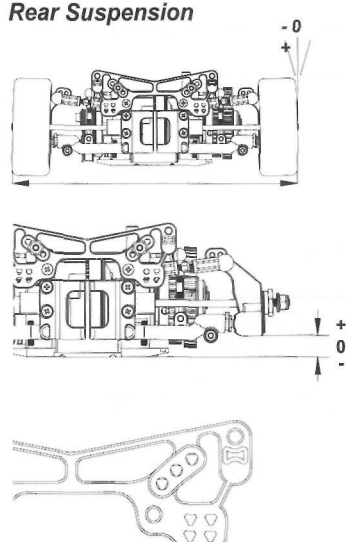
Front Diff. Oil # GS 3000 cps.

Rear Suspension 	<table style="width: 100%; border-collapse: collapse;"> <tr> <td style="width: 15%;">Track width</td> <td style="width: 15%; text-align: center;"><u>198</u></td> <td style="width: 15%;">mm</td> </tr> <tr> <td>Ride height</td> <td style="text-align: center;"><u>5.5</u></td> <td>mm</td> </tr> <tr> <td>Camber angle</td> <td style="text-align: center;"><u>3</u></td> <td>degrees</td> </tr> </table>	Track width	<u>198</u>	mm	Ride height	<u>5.5</u>	mm	Camber angle	<u>3</u>	degrees
Track width	<u>198</u>	mm								
Ride height	<u>5.5</u>	mm								
Camber angle	<u>3</u>	degrees								

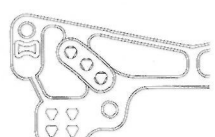
Rear shocks 	<table style="width: 100%; border-collapse: collapse;"> <tr> <td style="width: 15%;">Piston</td> <td style="width: 15%; text-align: center;"><u>2</u></td> </tr> <tr> <td>Oil #</td> <td style="text-align: center;"><u>GS 1000</u> cps.</td> </tr> <tr> <td>Spring</td> <td style="text-align: center;"><u>1.5</u> mm</td> </tr> <tr> <td>Tension</td> <td style="text-align: center;"><u>3.5</u> mm</td> </tr> </table>	Piston	<u>2</u>	Oil #	<u>GS 1000</u> cps.	Spring	<u>1.5</u> mm	Tension	<u>3.5</u> mm
Piston	<u>2</u>								
Oil #	<u>GS 1000</u> cps.								
Spring	<u>1.5</u> mm								
Tension	<u>3.5</u> mm								
Shock position Middle 									

Rear Diff. Oil # GS 3000 cps.

Engine			
Type	<u>GSV12RSX</u>	Fuel	<u>15%</u>
Gasket	<u>0.2</u> mm	Muffler	<u>standard</u>
Plug	<u>standard</u>		

Tires & Wheels			
Front	Tire	Rear	Tire

Clutch	
Clutch shoes	<u>stock 3 shoe</u>
Spring	<u>stock</u>
Clutch bell clearance	_____ mm
Clutch spring adj. nut	_____ mm
Gear Ratio	
1st	<u>14/48</u>
2nd	<u>18/44</u>

Body & Wing- VISION "S" Body

Comments

VISION RTR Set Up Sheet

Name _____ Date _____ Track _____	Track Conditions <ul style="list-style-type: none"> • Size: _____ • Traction: _____ • Surface: _____ • Open _____ • High _____ • Smooth _____ • Med _____ • Med _____ • Bumpy _____ • Tight _____ • Low _____
--	---

Front Suspension

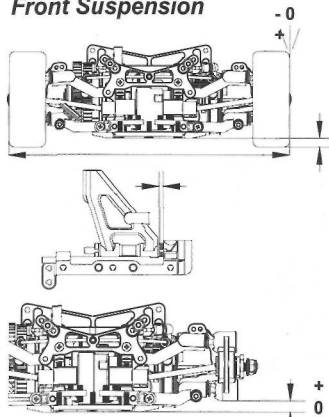

Track width _____ mm
 Ride height _____ mm
 Camber angle _____
 Caster angle _____ mm
 Toe angle _____ mm

Front shocks

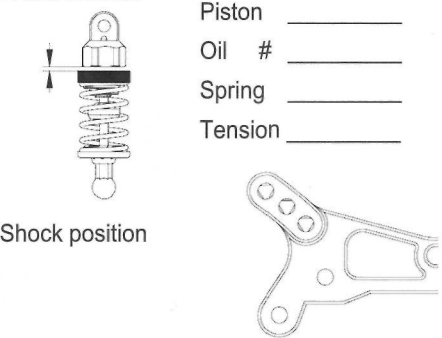

Piston _____
 Oil # _____
 Spring _____
 Tension _____
 Shock position _____

Front Diff. Oil # _____

Rear Suspension

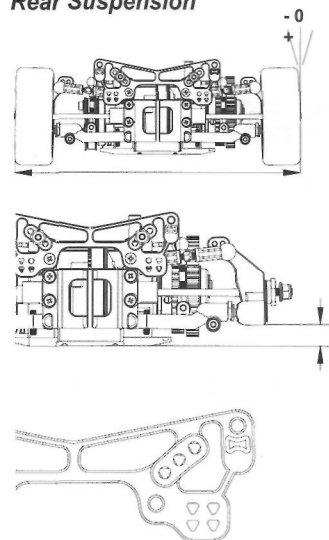

Track width _____ mm
 Ride height _____ mm
 Camber angle _____ mm
 Upper arm position _____
 Anti-roll bar _____

Rear shocks

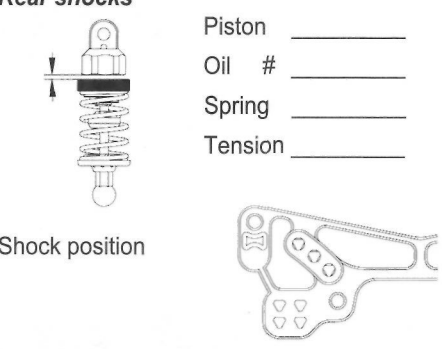

Piston _____
 Oil # _____
 Spring _____
 Tension _____
 Shock position _____

Rear Diff. Oil # _____

Engine

Type _____ Fuel _____
 Gasket _____ mm Muffler _____
 Plug _____

Clutch

Clutch shoes • Black _____
 Spring _____
 Clutch bell clearance _____ mm
 Clutch spring adj. nut _____ mm

Gear Ratio

1st _____
 2nd _____

Tires & Wheels

Front Tire _____ Rear Tire _____

Comments

Supplementary Instruction Sheet

8. Transmission & Shocks

EXPLODED VIEW(1)

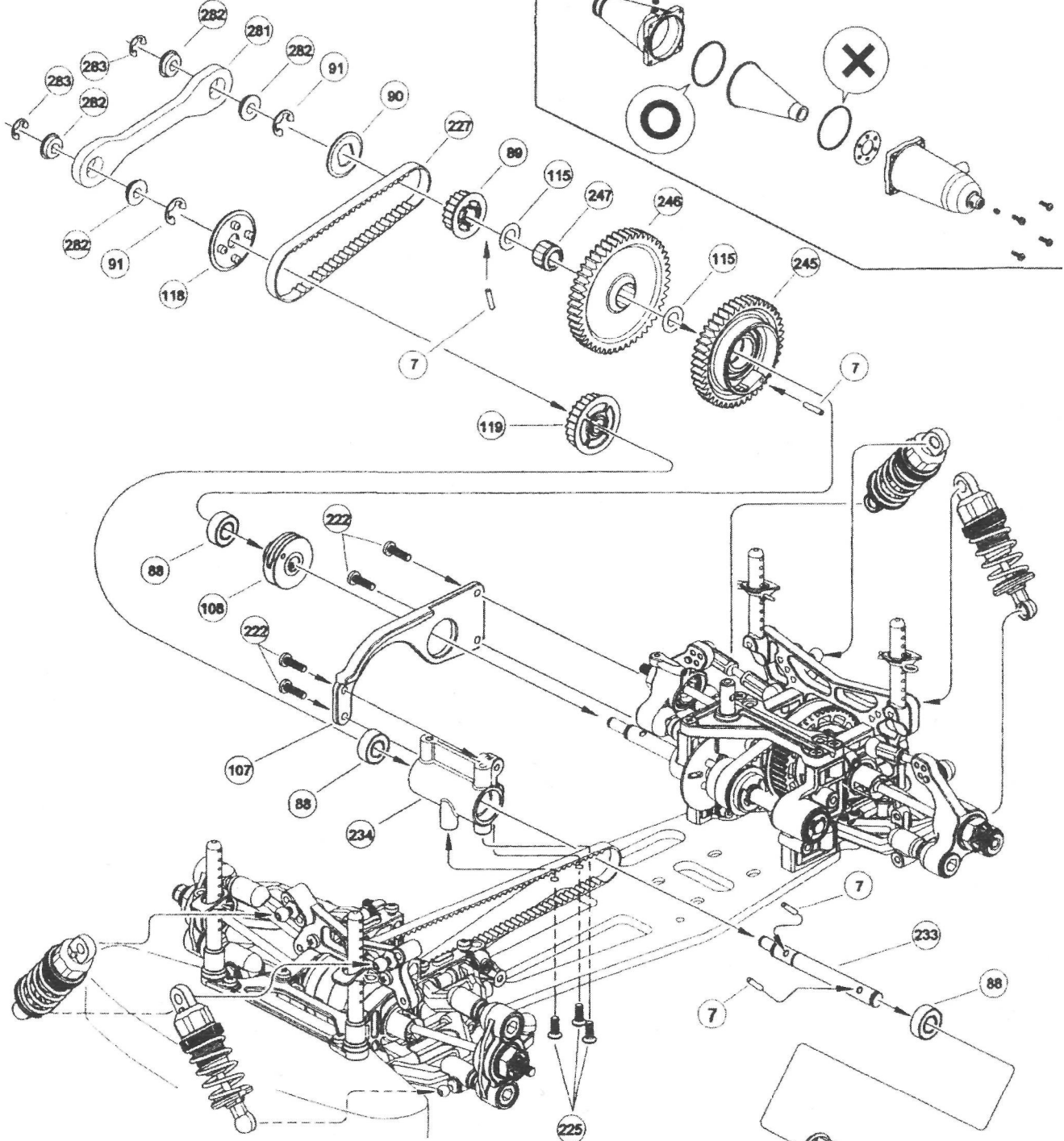

VISION RTR Key No./Part No. List

Key No.	Kit/Part Name	Q'ty	Part No.
281	RTR Belt Stiffener	1	GS-VS1220
282	5x8mm Flange Bearing	4	GS-690004
283	E Clip 4mm	2	GS-600011

